

Product Overview

The AX-WPS is a water point sensor for localized water point sensing - for example for use with drip trays etc. The units must be used with the AXIO range of AX-WLD2 range of water leak detectors. The excitation signal generated by the AX-WLD2 for the sensor connections ensures that the sensors do not degrade when exposed to damp for long periods.

The housing incorporates slotted lugs for ease of mounting and has 2m of cable, which can be cut to length according to the application.



Products Features

- Multiple units can connect to each AX-WLD sensor input.
- Slotted lugs for easy installation.
- Cable can be cut to length, or extended.
- Robust housing.

Product Specifications

Housing

Material: Black ABS
Protection Rating: UL94-HB
Cable Length: 2m

Probes:

Material: Stainless Steel (304)
Dimensions: 13mm x 3mm diameter
Country of origin: UK

Dimensions

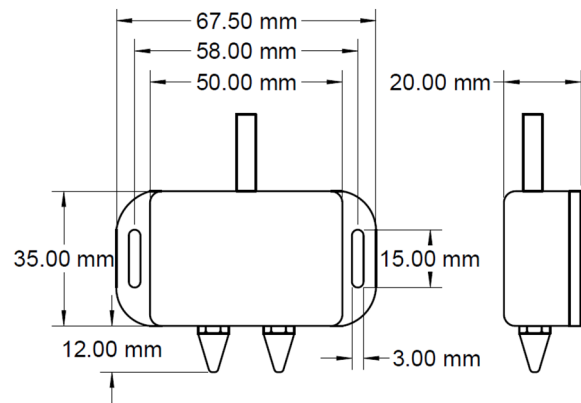

Installation

1. Fix the AX-WPS in the location where leak detection is required.
2. The AX-WPS is fitted with 2m of cable. This can then be increased to a maximum of 200m to the AX-WLD2 alarm module, via a junction box if necessary.
3. Connect the cable to the relevant sensor input on the alarm module (polarity independent).
4. Apply power to the AX-WLD2, and adjust the relevant pot on the module anti-clockwise until the relevant 'Sensor LED' illuminates, and then clockwise until the 'Sensor LED' extinguishes.
5. Test the sensor by placing a damp cloth over the stainless steel probes to simulate a water leak. The AX-WLD2 relay will indicate an alarm. Remove the cloth and the relay will turn off.
6. More than one AX-WPS can be connected to each sensor input on the AX-WLD2, provided the total cable run does not exceed 200m.

Please note: Failure to use the AX-WPS with an AX-WLD2 will result in premature failure of the unit, and will not be covered by warranty.

Product Order Codes

Order Code	Description
AX-WPS	Water Point Sensor & 2m Cable
AX-WPS-5	Water Point Sensor & 5m Cable