

AX-PPR3VI-105

Three Phase Power Regulators - 105kW (Panel Mount)



Product Overview

The AX-PPR3VI-105 power regulators (thyristors) provide continuously adjustable control of electric heating loads from a BMS controller or a similar control system. Typical applications include electric heating coils, heating cables, and electric furnaces. They use solid-state switching with zero-crossing technology to minimise RFI and ensure precise switching control. Units feature over-temperature protection with automatic reset and alarm output, and are designed for panel mounting. The integral cooling fan activates automatically when required, and no additional heatsinks or external fans are necessary.



Product Features

- 0-10V DC/4-20mA Control Input
- Burst-fire control
- Auto-reset over-temperature protection
- 24V AC/DC-Powered and Self-Powered Models
- Alarm Output (SPCO contacts)
- Two Internal Semiconductor Fuses

Product Specifications

Input:		0-10V DC (>15KOhms), 4-20mA (500Ohms)
Control Power Supply (Non-SP):		24V AC \pm 10% or 22 - 40V DC
Power Consumption (Non-SP):		110mA @ 24V DC (2.7VA) or 185mA @ 24V AC (4.5VA)
Alarm Output:		SPCO contacts; max rating 5A @ 250V AC
Maximum Heater Duty:		105kW
Rated Load:		152A @ 40°C
Rated Supply:		380-440V AC / 50-60Hz
Internal Fuses:	L2 and L3 only	2 x 200A aR-type fuses
Control Isolation:		3,000V
Dissipated Heat:		345W
Terminals:	Control	Rising clamp for 0.5-1.5mm ² wires; two part pluggable connectors
	Power	M6 stud connections
Ambient Temperature Range:		0 to 55°C. Note: The units are rated at 40°C. If using at higher ambient temperature de-rate the unit by 10% for every 5°C above 40°C.
Over-Temperature:		Load is disconnected when heatsink temperature exceeds 90°C. Load is reconnected when heatsink temperature falls below 85°C
Dimensions:		225 x 192x 188 mm. Refer to page 3 for fixing holes
Weight:		4.9Kg
Country of Origin:		United Kingdom

Product Order Codes

Order Code	Description
AX-PPR3VI-105	Panel Mount Three-Phase Power Regulator, 105kW, 24V AC/DC Powered
AX-PPR3VI-105-S	Panel Mount Three-Phase Power Regulator, 105kW, Self-powered
FUSPPR200	Replacement Fuse for AX-PPR3VI-105 Models

AX-PPR3VI-105

Three Phase Power Regulators - 105kW (Panel Mount)



Dimensions

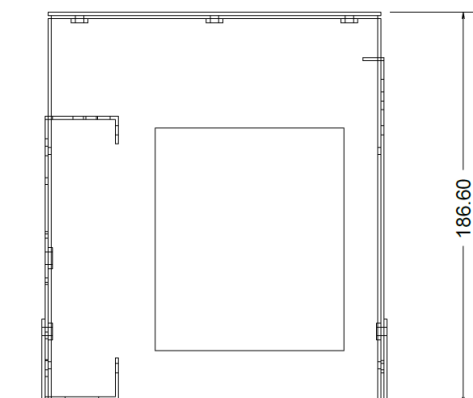
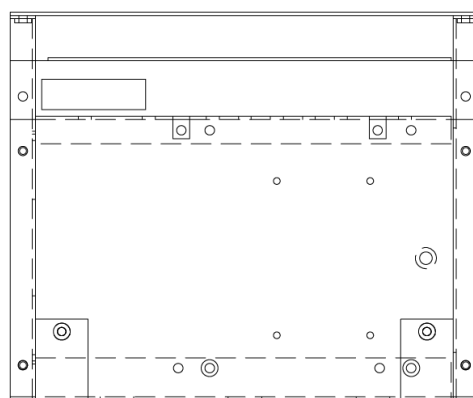
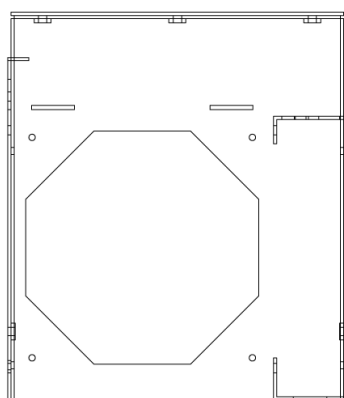
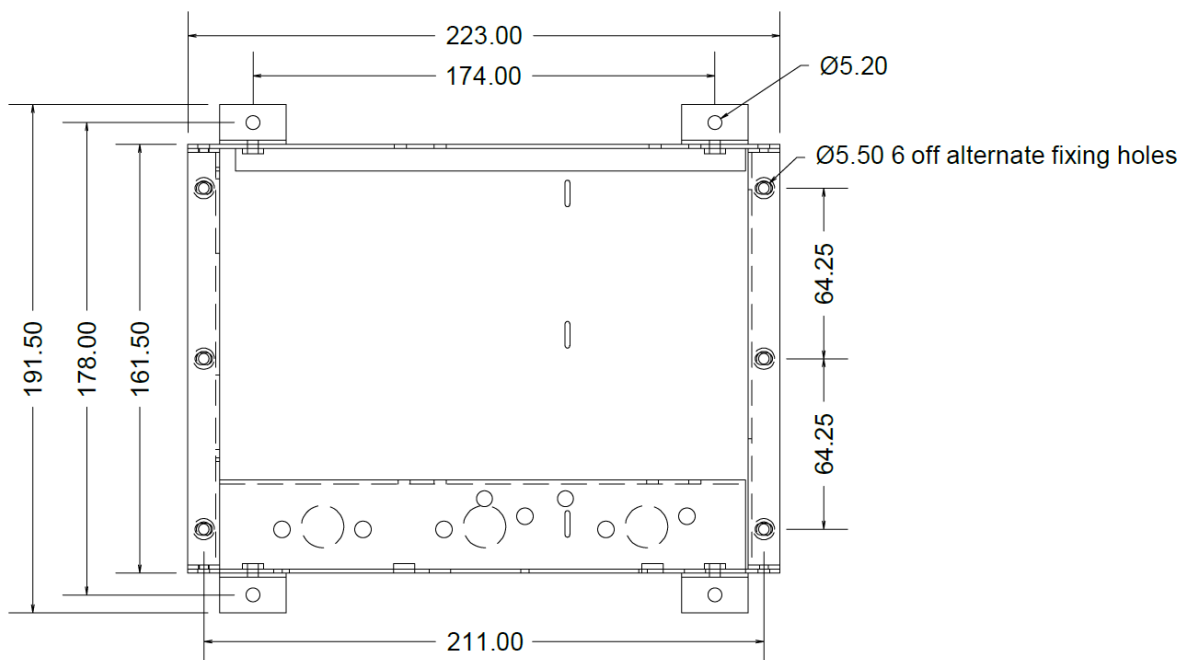

Mounting brackets

The mounting brackets and earth bolts are not factory-fitted to the unit. They are supplied separately in a package inside the main packaging.

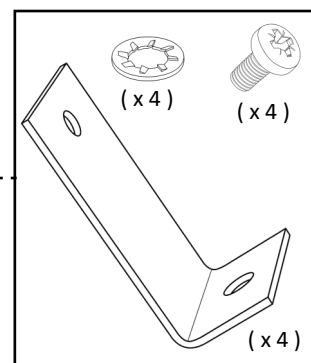
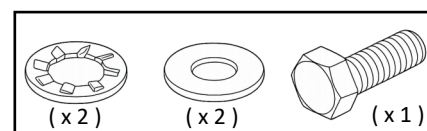
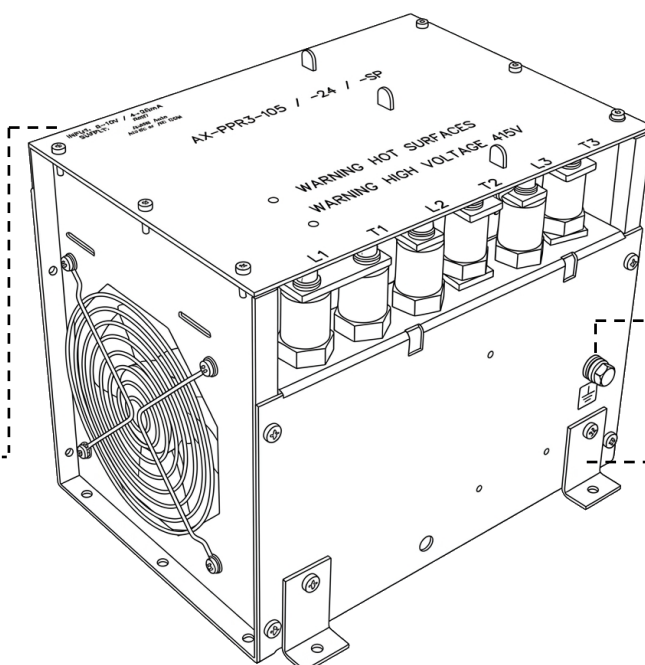
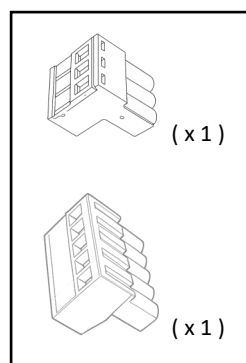

Operation

The AX-PPR3VI-105 series controls electric heating loads in linear proportion to the applied 0-10V DC or 4-20mA control signal. Solid-state semiconductor devices switch the load using burst-fire control combined with zero-crossing point switching, which virtually eliminates RFI emissions. Burst-fire control refers to the method where the AC load is switched fully on for an integer number of complete half cycles in a burst.

Assuming a cycle time of 4 seconds:

- With a control input of 10V / 20mA, the load will be ON continuously (100% duty).
- With a 5V / 12mA input, the load will be ON for 2 seconds and OFF for 2 seconds (50% average power).
- With a 2.5V / 8mA input, the load will be ON for 1 second and OFF for 3 seconds (25% average power).
- With a control input of 0V / 4mA, the load will be OFF continuously (0% duty).

It is important to note that whenever the load is switched ON, full load current is drawn for that period of control time.

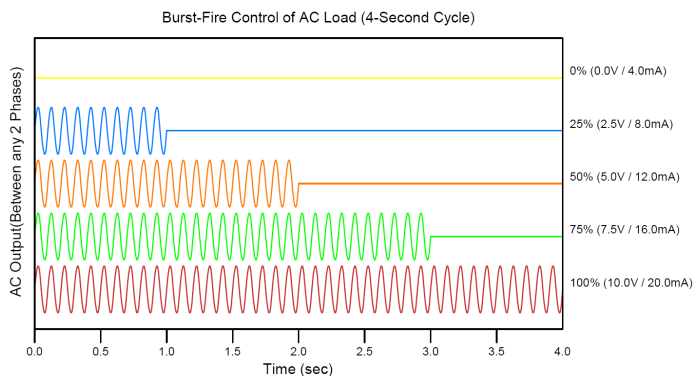

Installation

Installation should be done by a suitably qualified technician in conjunction with any guidelines for the equipment it is to be connected to and any local regulations.

The power regulators must be mounted vertically on a panel. Ensure a minimum clearance of 100 mm on all sides of the unit to allow adequate airflow and prevent restriction of ventilation around the enclosure.

CAUTION!

In normal operation the heatsink surface can exceed 90°C. Dangerous potentials exist on the unit and particular care should be taken.

Load Supply and Protection

It is recommended that a suitably rated contactor is installed in the supply to the unit. The contactor coil should be interrupted by sensors for over temperature in the heater and also ideally upon air flow loss. Fuses or MCBs (miniature circuit breakers) are required to provide overload protection.

Maximum Heating Load

The power rating of the units are given as a guide. The maximum current (which is dependent on the actual supply voltage and heating load) as shown in the specification table must not be exceeded.

Earthing

The M6 earth bolt must always be bonded to a good Earth. This earth bond lead should be appropriately rated according to the maximum load and fusing in the installation. Refer to BS7671.

Control Supply

The control circuitry is fully isolated from the load supply. The non-SP unit requires a 24 Vac/dc control supply. The control supply common is linked to the 0-10V / 4-20mA input signal common.

Control Signal

All low voltage signal and supply cables should be kept separate from high voltage or mains cables, separate trays or conduit should be used. Screened cable should be used for connections to BMS Controllers. Where possible the cable screen should be connected to a functional earth (not mains safety earth). The screen should be earthed at one end only to avoid earth loops.

The device can operate on either 4-20mA or 0-10V DC control signal. If both signals are connected, 4-20mA will be selected for control.

Ventilation

The ambient temperature of the installation should not exceed 55°C. If necessary, enclosures or control panels should be ventilated with a cooling fan. See note in product specification for de-rating to be applied above ambient temperatures of 40°C.

Cycle Time

The cycle time is preset to 4 seconds. Adjustment(1-30s) is possible using the cycle time potentiometer but is not normally required.

Over Temperature Monitoring

An electronic thermal cut-out is fitted to the heatsink to protect against over-temperature. The unit will switch off the load if the heatsink temperature exceeds approximately 90 °C and will reconnect the load once the temperature has dropped below 85 °C. The alarm output will also change state. Under normal operating conditions, the heatsink temperature will not reach 90 °C, but this may occur, for example, if the ambient temperature exceeds 40 °C. The alarm output is an SPCO contact, which changes state on over-temperature detection or on control-voltage power failure. These units are fitted with an integral fan, which turns on and off automatically as required to control the heatsink temperature.

Internal Fuses

These Power Controllers feature two internal quick acting semiconductor fuses to protect the switching devices. There is no fuse fitted to the L1-T1 terminals, which is a straight through connection.

Internal Fuse Replacement

Disconnect from the main supply before attempting to remove the cover. Remove the main cover earth strap, then the six cover-retaining screws. Replace the fuse and reinstall the cover panel. The main cover earth strap must be refitted before reapplying power.

Connections

• Control

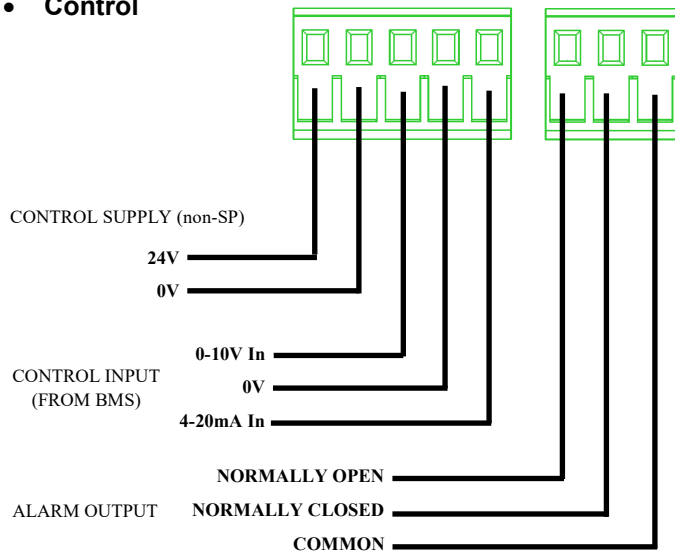

Note that the alarm contacts are shown in their normal state when energized. They change state upon loss of power or during an over-temperature condition.

• Load

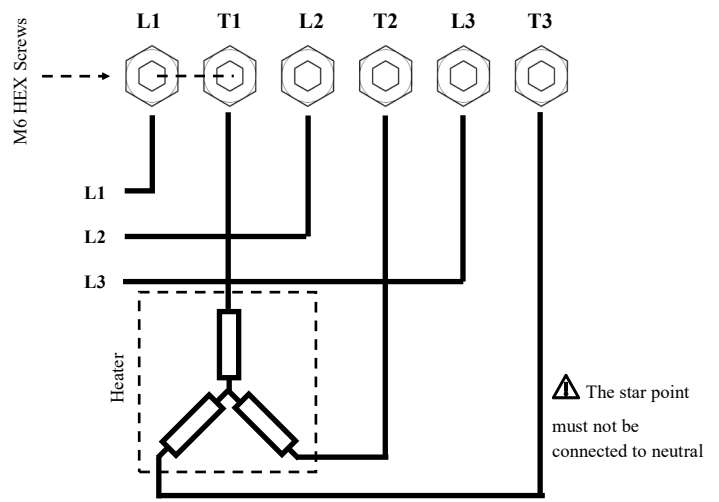

Ensure all power connections are securely tightened without excessive torque. Verify that the maximum possible conductor contact area is maintained at the terminals.

Load Configuration: The load may be connected in a delta configuration when using heater elements rated for 415 V.

AX-PPR3VI-105



Three Phase Power Regulators - 105kW (Panel Mount)

Recommended Minimum Control Wiring

- AX-PPR3VI-105-24

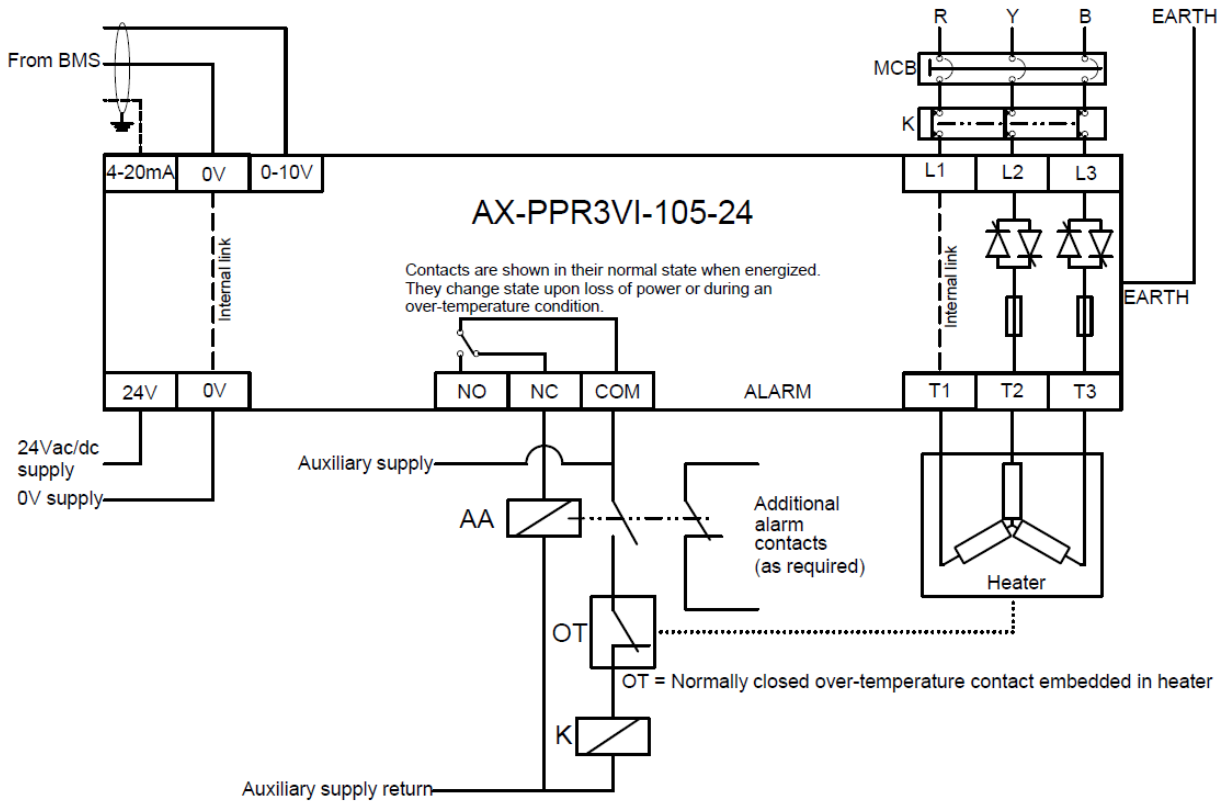

- AX-PPR3VI-105-SP

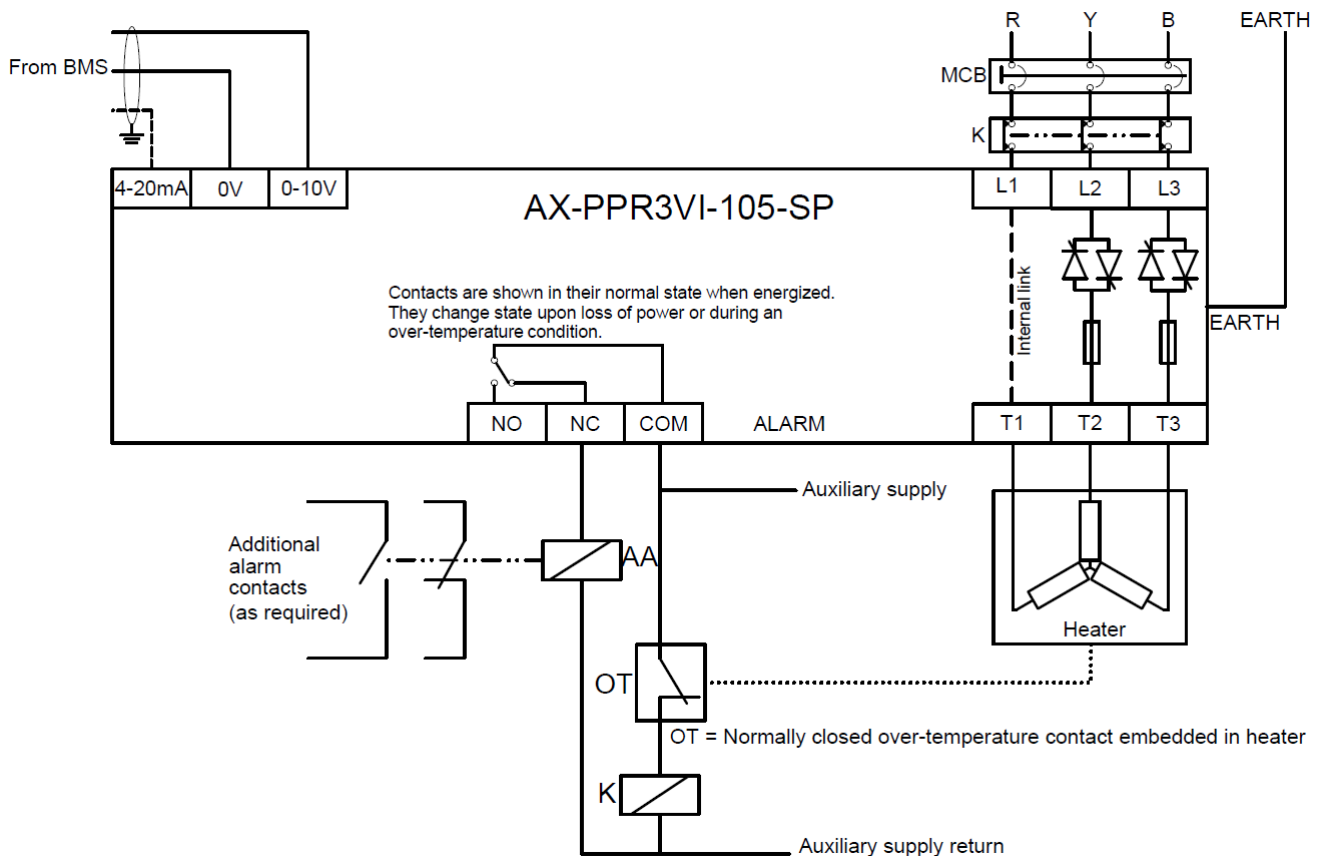

Every effort has been taken in the production of this data sheet to ensure accuracy. Annicom do not accept responsibility for any damage, expense, injury, loss or consequential loss resulting from any errors or omissions. Annicom has a policy of continuous improvement and reserves the right to change this specification without notice.