

AX-PPR3-72 & -105

72kW and 105kW Three Phase Power Regulators



Product Overview

The AX-PPR3-72 and AX-PPR3-105 Power Regulators (thyristors) provide continuously adjustable control of electric heating loads from a BMS Controller or similar. Applications include electric heating coils, heating cables and electric furnaces. The AX-PPR3 Series use solid-state switching with “zero crossing technology” to minimise RFI and provide accurate switching control. All Power Controllers in this series feature Over Temperature Protection with automatic reset and Alarm Output, LED Indication of Output ON and are designed for panel mounting. The AX-PPR3-72 and AX-PPR3-105 feature an integral cooling fan which turns on automatically when required.



Products Features

- 0-10Vdc Control Input
- 72kW and 105kW Models
- Burst-fire Control
- Auto Reset Over Temperature Protection
- 24Vac/dc Powered
- Alarm Output
- LED Indication
- Two internal semi-conductor fuses

Product Specifications

Input:	0-10Vdc at 0.2mA maximum
Control Power Supply:	24Vac \pm 10% or 22 - 40Vdc
Power Consumption:	110mA @ 24Vdc (2.7VA) or 185mA @ 24Vac (4.5VA)
Alarm Output:	250Vac at 5A VFC - contact closed when over temperature alarm is active or on removal of Control Supply
Maximum Heater Duty:	See detailed table on Page 2
Rated Load:	See detailed table on Page 2
Rated Supply:	380-440Vac / 50-60Hz
LED Indication:	ON when output is on
Internal fuses:	L1 and L2 only 2 off 200A BS88:4 Semiconductor Type
Control isolation:	3,000V
Dissipated Heat:	See detailed table on Page 2
Terminals:	Control Rising Clamp for 0.5-1.5mm ² Cable Power See detailed table on Page 2
Ambient Temperature Range:	0 to 55°C. Note: The units are rated at 40°C. If using at higher ambient temperature de-rate the unit by 10% for every 5°C above 40°C.
Over temperature:	Load is disconnected when heatsink temperature exceeds 90°C Load is reconnected when heatsink temperature falls below 85°C
Dimensions:	270 x 250 x 200mm. Refer to drawing for fixing holes
Weight:	7.1kg
Country of Origin:	United Kingdom

Product Order codes

Order Code	Description
AX-PPR3-72	72kW Three Phase Power Regulator
AX-PPR3-105	105kW Three Phase Power Regulator

Specification continued

Product code	Nominal Heater Duty	Max. Load per phase Amps @40°C	Rated Supply	Maximum Dissipated heat	Power Terminal Cable sizes	Power Terminal tightening Torque and detail
AX-PPR3-72	72kW	104A	380-440V / 50-60Hz	335W	6-35mm ²	3Nm slotted screw
AX-PPR3-105	105kW	152A	380-440V / 50-60Hz	487W	16-70mm ²	7mm

Operation

The AX-PPR3 series control electric heating loads in linear proportion to the applied 0-10Vdc control signal. Solid-state semiconductor devices switch the load using burst-fire control, combined with zero-crossing point switching which virtually eliminates RFI emissions.

Burst-fire control is where the ac load is switched fully on for an integer number of complete half cycles in a burst. Assume a cycle time of 4 seconds: With a 0-10Vdc Input Signal of 10V the load will be on all of the time i.e. fully ON. At 5V input the load will be switched ON for 2 seconds and OFF for 2 seconds, i.e. on average the load is at 50% power. At 2.5V input the load will be switched ON for 1 second and OFF for 3 seconds, i.e. on average the load is at 25% power. Note that whenever the load is switched ON, full load current will be drawn for that period of control time.

Installation and configuration

The AX-PPR3 series Power Regulators must be mounted vertically on a panel (see connection drawing). Allow a minimum of 100mm between units mounted in a vertical plane. It is important that free air movement around the enclosure is not restricted.

CAUTION!

In normal operation the heatsink surface can exceed 90°C. Dangerous potentials exist on the unit and particular care should be taken.

Electrical Installation:

Installation must be carried out by a suitably trained electrician, and in accordance with the relevant statutory regulations. The Power Terminals must be tightened to the torque specified in the Product specification table (above).

Load Supply and Protection:

It is recommended that a suitably rated contactor is installed in the supply to the unit. The contactor coil should be interrupted by sensors for over temperature in the heater and also ideally upon air flow loss. Fuses or MCB's (miniature circuit breakers) are required to provide overload protection.

Maximum Heating Load:

The power rating of the units are given as a guide. The maximum current (which is dependant on the actual supply voltage and heating load) as shown in the specification table must not be exceeded.

Earthing:

The M6 earth bolt must always be bonded to a good Earth. This earth bond lead should be appropriately rated according to the maximum load and fusing in the installation. Refer to BS7671.

Control Supply:

The control circuitry is fully isolated from the load supply and requires a 24Vac/dc supply. The control supply common is linked to the 0-10V Input Signal common.

Control Signal:

All low voltage signal and supply cables should be kept separate from high voltage or mains cables, separate trays or conduit should be used. Screened cable should be used for connections to BMS Controllers. Where possible the cable screen should be connected to a functional earth (not mains safety earth). The screen should be earthed at one end only to avoid earth loops.

Ventilation:

The ambient temperature of the installation should not exceed 55°C. If necessary, enclosures or control panels should be ventilated with a cooling fan. See note in product specification for de-rating to be applied above ambient temperatures of 40°C.

Cycle Time:

The Cycle Time is preset for 4 seconds. Adjustment is possible using the Cycle Time potentiometer, but is not normally required.

Over Temperature Monitoring:

An electronic thermal cut-out is fitted to the heatsink to protect against over temperature. The AX-PPR3 series will switch off the load if the heatsink temperature exceeds approximately 90°C and will reconnect the load once the heatsink temperature has dropped below 85°C. The Alarm output will also change state. Under normal operating conditions the heatsink temperature will not reach 90°C but this might occur, for example, if the ambient temperature exceeds 40°C.

The Alarm output is an isolated volt-free contact, which closes on over-temperature detection, or on control voltage power fail. These units are fitted with an integral fan. The fan will turn on and off automatically as required to control the heatsink temperature.

AX-PPR3-72 & -105



72kW and 105kW Three Phase Power Regulators

Internal Fuses

These Power Controllers feature two internal quick acting semiconductor fuses to protect the switching devices. There is no fuse fitted to the L3-T3 terminals, which is a straight through connection.

Internal Fuse Replacement

Disconnect from the main supply before attempting to remove the cover. Remove the main cover earth strap and then the four cover retaining screws. The main cover earth strap must be fitted before reapplying the power.

Connections

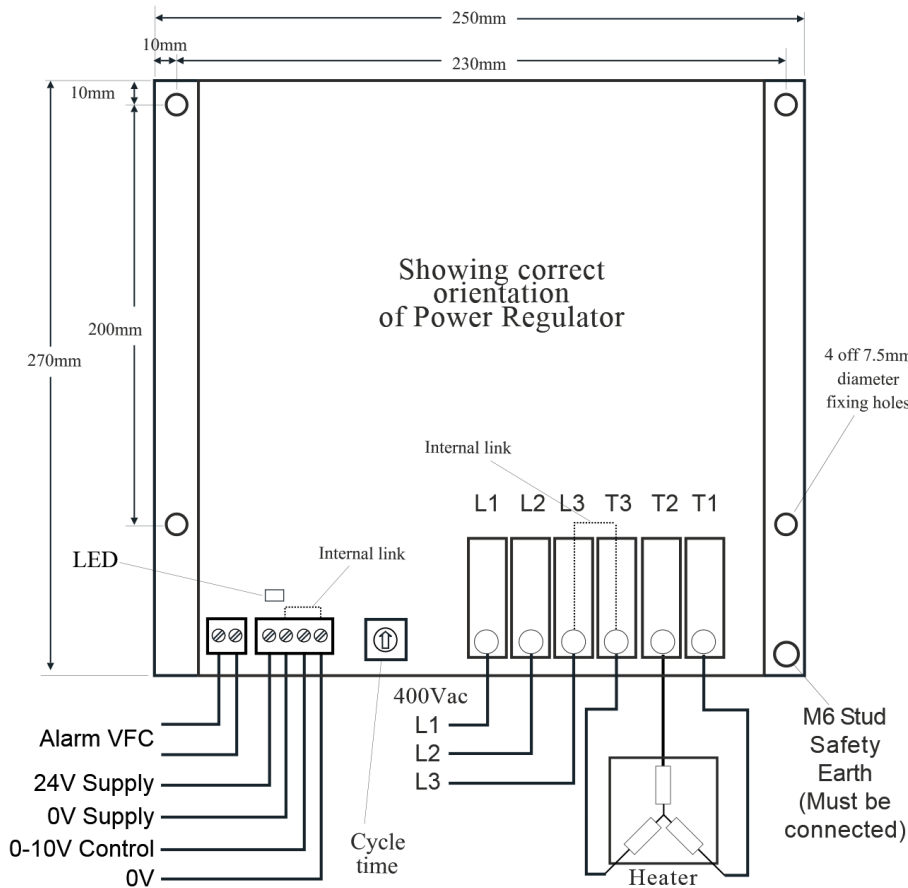

All models:

Terminals L3 and T3 are connected internally. If the load is connected in star, the star point must not be connected to neutral.

It is imperative that the power connections are fully tightened, without excessive force, and ensure the maximum area of cable is in contact with the terminals.

The M6 Earth bolt must be used with an appropriately rated cable to bond the unit to an earth point.

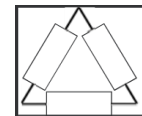

Alternative heater load - star connected for 400V elements

AX-PPR3-72 & -105

72kW and 105kW Three Phase Power Regulators



Recommended minimum control wiring

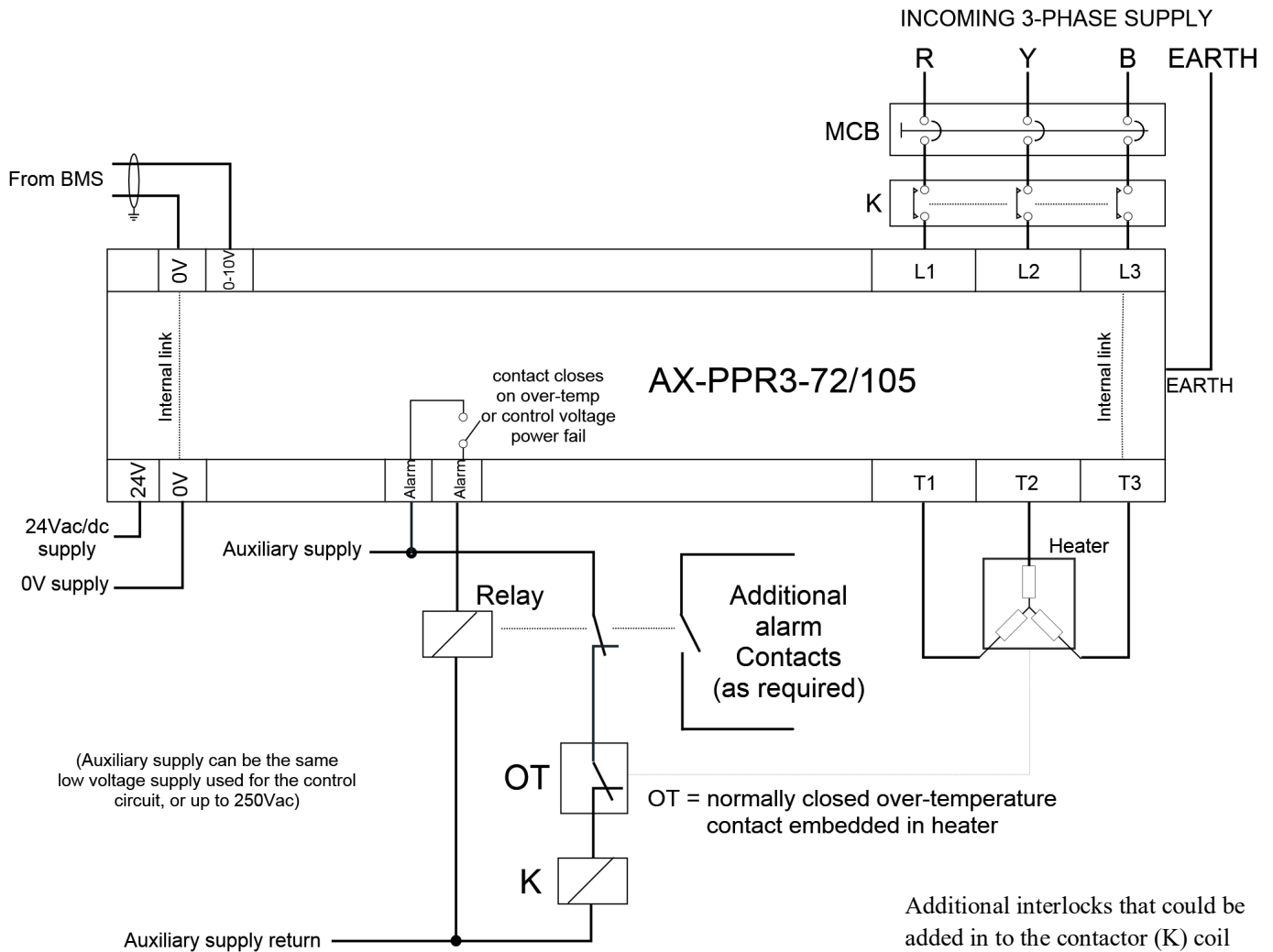

(Auxiliary supply can be the same low voltage supply used for the control circuit, or up to 250Vac)

AX-PPR3-72/105

Additional alarm Contacts (as required)

OT = normally closed over-temperature contact embedded in heater

Additional interlocks that could be added in to the contactor (K) coil circuit:

- Emergency stop signal
- Fire signal
- Start/Stop from BMS
- Air flow switch

Datasheet Contents

Every effort has been taken in the production of this data sheet to ensure accuracy. Annicom do not accept responsibility for any damage, expense, injury, loss or consequential loss resulting from any errors or omissions. Annicom has a policy of continuous improvement and reserves the right to change this specification without notice.