

AX-PPR3-180-280-400

180/280/400kW Three Phase Power Regulators

AXIO

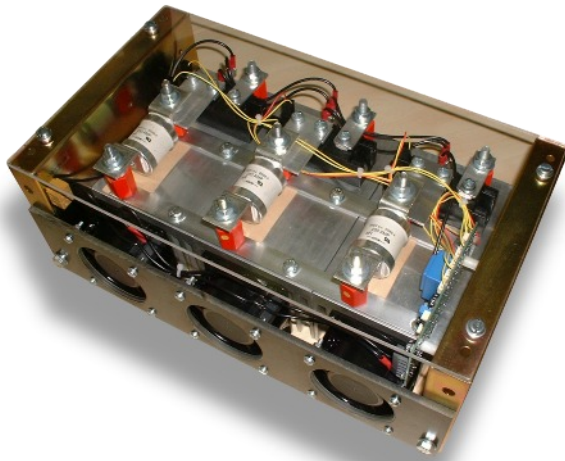

Product overview

The AX-PPR3-xxx Power Regulators are designed to provide continuously adjustable control of electric heating loads from a BMS Controller or similar. Applications include electric heating coils, heating cables and electric furnaces. The AX-PPR3-180/280/400 use Solid-state switching with “zero crossing technology” to reduce RFI problems and provide accurate switching control. LED Indication of Output ON and are designed for panel mounting. The units feature three cooling fans which turns on automatically when the built in thermostat exceeds 60°C. No additional heatsinks or fans are needed.

Features

- 0-10Vdc Control input
- 180 / 200 & 400kW Models
- Fused to meet your load requirement
- Built in Thermostat to switch on integral fans
- Three Integral Fans (400 has one large fan)
- Controls all three phases
- LED Indication

Product specifications

Input:		0-10Vdc
Fan Supply:		230Vac 50/60Hz
Max. Heater Duty:	PPR3-180	180kW
	PPR3-280	280kW
	PPR3-400	400kW
Dissipated Heat:		Depends on load
Rated Supply:		415Vac / 50/60Hz
Power Consumption:		110mA @ 24Vdc (2.7VA) or 185mA @ 24Vac (4.5VA)
Fuses:		3 x fuses dependant on load
LED Indication:		ON when output is on
Terminals:	Control	M8 Stud connections
	Power	M8 Stud connections
Ambient Temperature Range:		0 to 45°C
Dimensions:		See drawings
Country of Origin:		United Kingdom

Order codes

AX-PPR3-180	180kW Three Phase Power Regulators
AX-PPR3-280	280kW Three Phase Power Regulators
AX-PPR3-400	400kW Three Phase Power Regulators

© Copyright Annicom 2016. All Rights Reserved

Annicom Ltd

Unit 21, Highview, Bordon, Hampshire. GU35 0AX

Tel: +44 (0)1420 487788 Fax: +44 (0)1420 487799

Email: sales@annicom.com Website: www.annicom.com

Installation & configuration

The AX-PPR3 Large Power Regulators are designed for mounting on a vertical panel. It is important that free air movement around the unit is not restricted. Allow sufficient air space between adjacent units to allow optimum performance of the heatsink. Installation must be carried out by a suitably trained electrician, and in accordance with the relevant statutory regulations. These units MUST be earthed using the M6 stud provided and the Load Terminals must be tightened to the torque specified in the Specification Table.

Load Supply and Back-up Protection:

The AX-PPR3 Large Power Controllers feature internal quick acting semiconductor fuses to protect the switching devices. The Load Cables must be protected by external appropriate fuses or MCB's in the usual manner. Load cables must be sized such that they are rated in excess of the fuse ratings. If in doubt, contact Axio for advice.

Ratings:	Output	Current	Fuse	
AX-PPR3-180	108kW	150A	180A MT	FM4 Semiconductor Type
	117kW	163A	200A MT	FM4 Semiconductor Type
	153kW	213A	250A MT	FM4 Semiconductor Type
	165kW	229A	280A MT	FM4 Semiconductor Type
AX-PPR3-280	192kW	267A	315A MT	FM4 Semiconductor Type
	228kW	317A	355A MT	FM4 Semiconductor Type
	236kW	328A	400A MMT	FM4 Semiconductor Type
AX-PPR3-400	324kW	450A	500A MMT	FM4 Semiconductor Type
	378kW	525A	630A MMT	FM4 Semiconductor Type

Semiconductor Fuse Replacement:

Disconnect from the main supply before attempting to remove the cover. Remove the main cover earth strap and then the four cover retaining screws. The main cover earth strap must be fitted before re-applying the power.

Cables:

Screened cable should be used for connections to BMS Controllers, where possible the cable screen should be connected to a functional earth (not mains safety earth); normally the screen should be earthed at one end only to avoid earth loops.

Cycle Time:

The Cycle Time is preset. An 0-10Vdc Input Signal of 5V equates to the load being at 50% ON and likewise with an input of 2.5V load will be 25% ON. A 10V input will equal 100% i.e. full ON.

Operation

The AX-PPR3-150 is designed to control electric heating loads in linear proportion to the incoming 0-10Vdc control signal. Control is by solid-state semiconductor devices which control the load using pulse width modulation (PWM)N techniques. These devices feature "zero crossing point" switching of the AC load which virtually eliminates RFI problems.

CAUTION!

In normal operation the heatsink surface can exceed 90°C. Dangerous voltages exist inside the unit and particular care should be taken. The AX-PPR3-150 Power Controllers must be installed in accordance with the relevant statutory regulations and installation must be carried out by an experienced and fully qualified engineer.

Ventilation

The AX-PPR3-150 are designed to operate in a maximum ambient temperature of 45°C. Which should not be exceeded. If necessary, enclosures or control panels should be ventilated with a cooling fan.

Over Temperature Monitoring

A thermostat is fitted to the unit to protect against over temperature. When the temperature of the unit reaches 60°C the three fans places above the Thyristors are automatically switched on.

AX-PPR3-180-280-400

180/280/400kW Three Phase Power Regulators



AX-PPR3-180 Dimensions

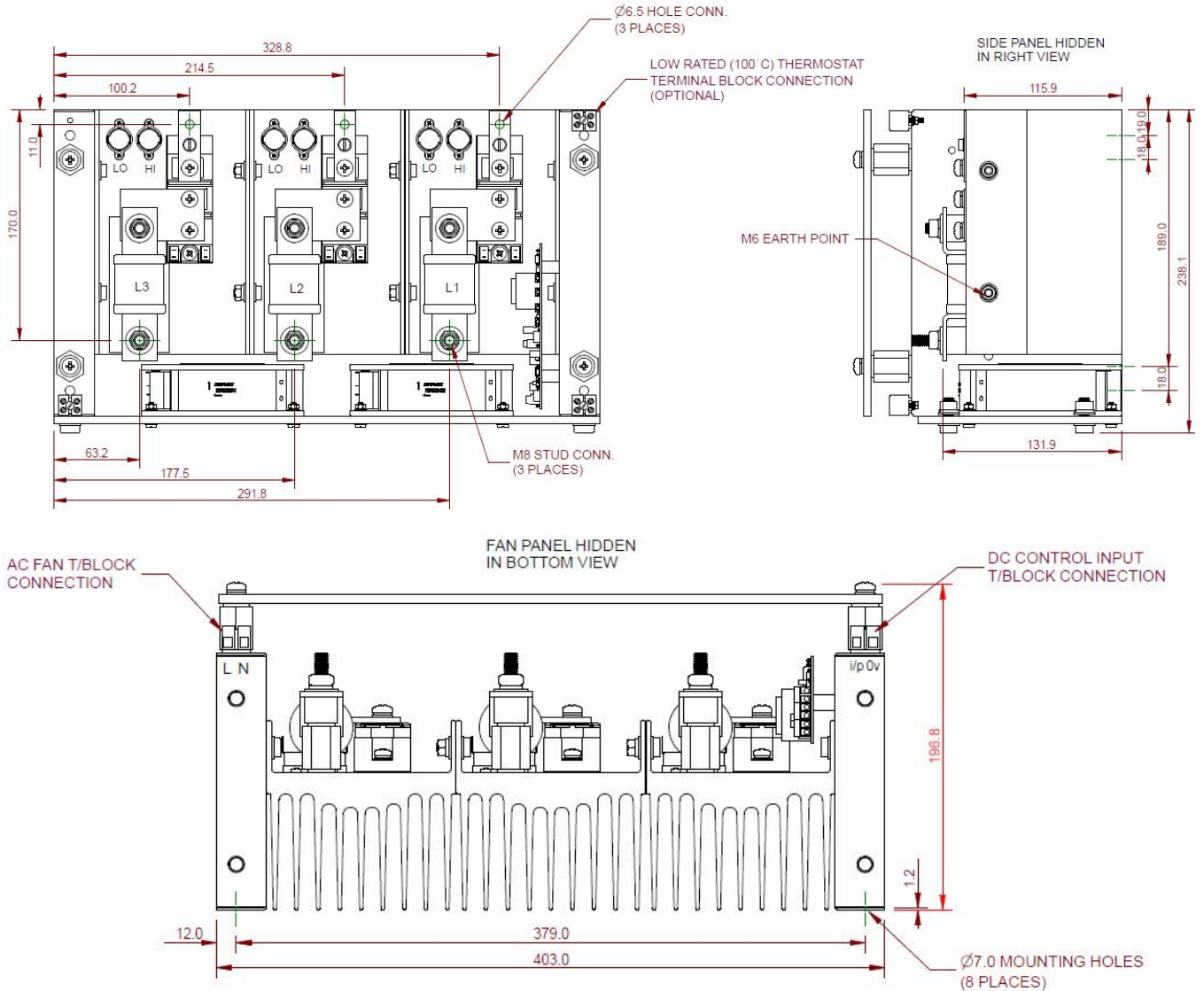

Connection

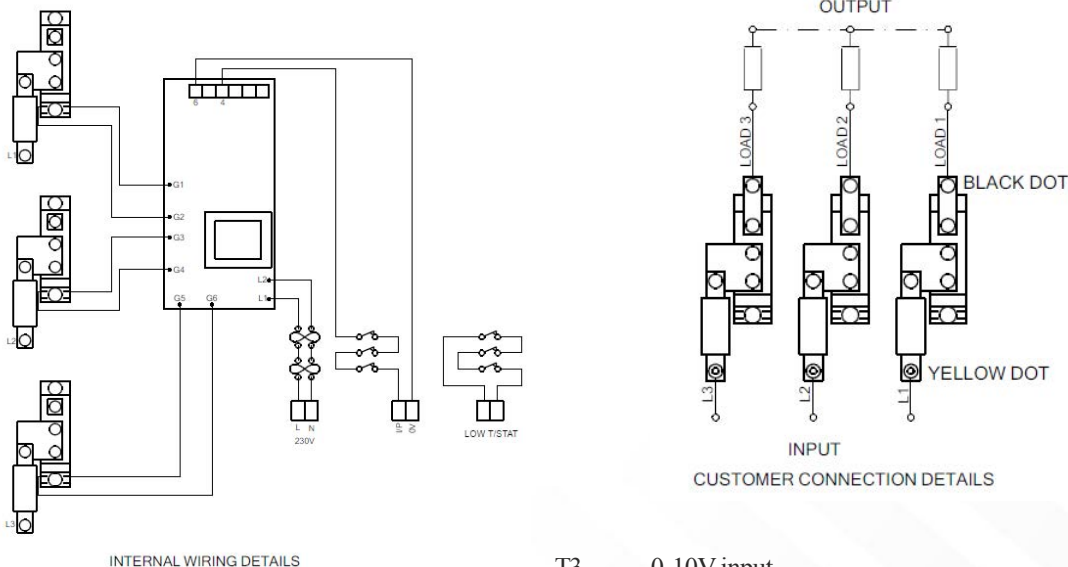

NOTE: It is imperative that the power connections are fully tightened, without excessive force, and ensure the maximum are of cable is in contact with the terminals.

- T3 0-10V input
- T4 0-10V input
- T5 0V
- T6 0V

Connection :- (do not touch inhibit link T1 & T2)
the three yellow dots are the input
the three black dots are the output

AX-PPR3-180-280-400

180/280/400kW Three Phase Power Regulators



For units up to a current load of 132 Amps at 45°C

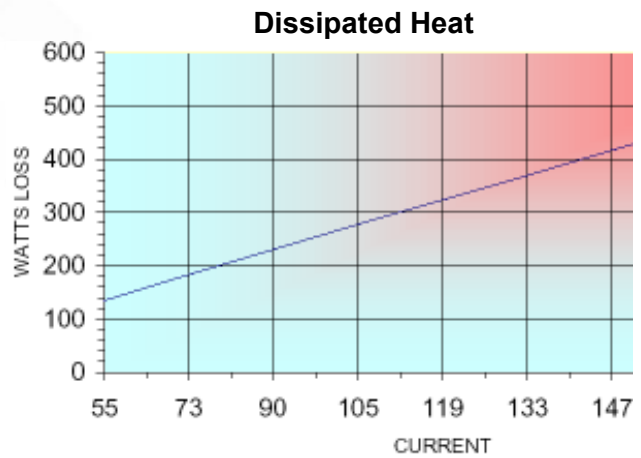
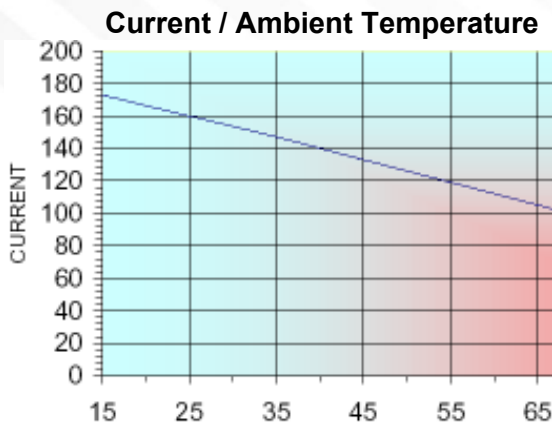

For units up to a current load of 190 Amps at 45°C

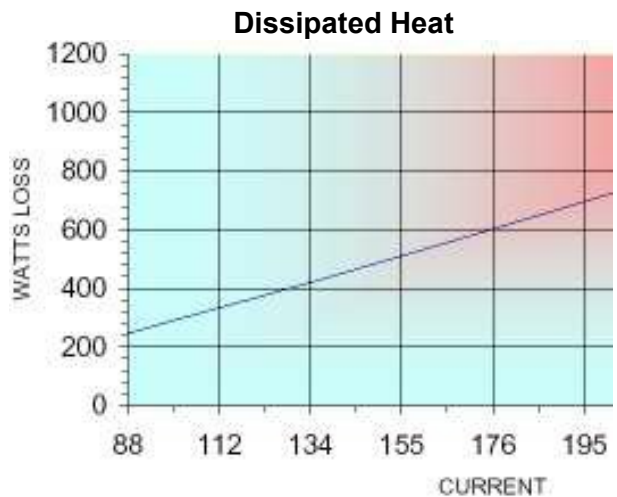
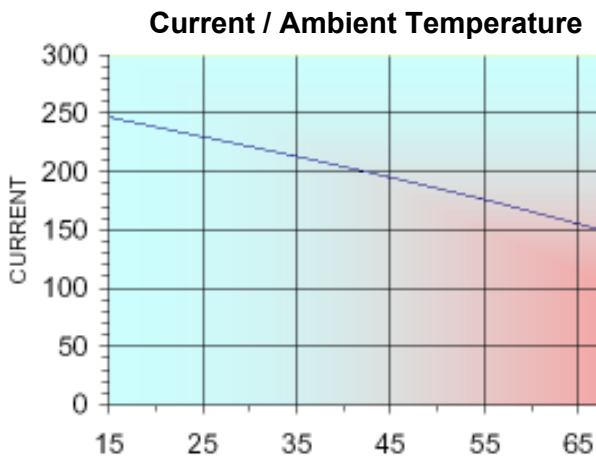

For units up to a current load of 280 Amps at 45°C

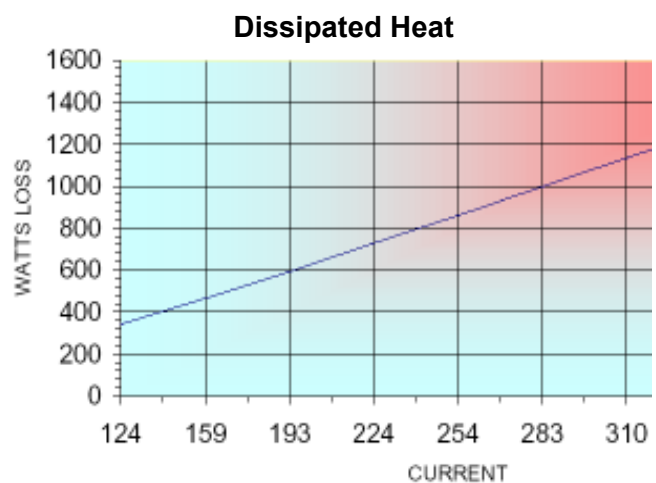
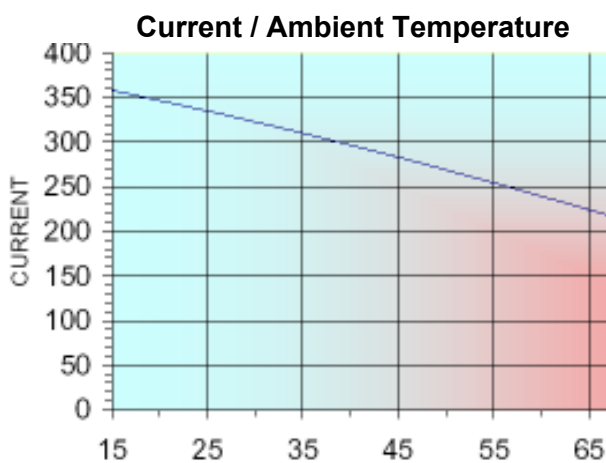

AX-PPR3-180-280-400

180/280/400kW Three Phase Power Regulators



AX-PPR3-280 Dimensions

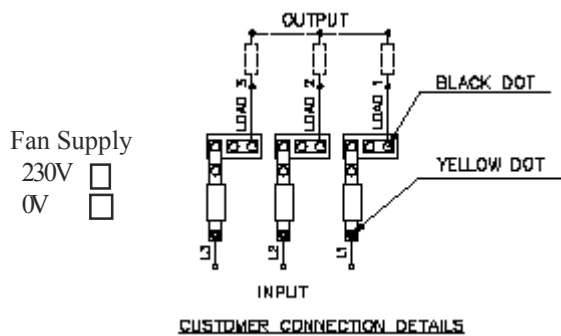
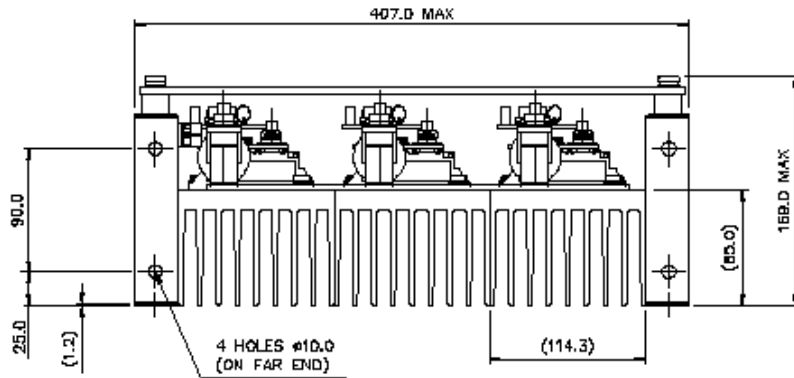
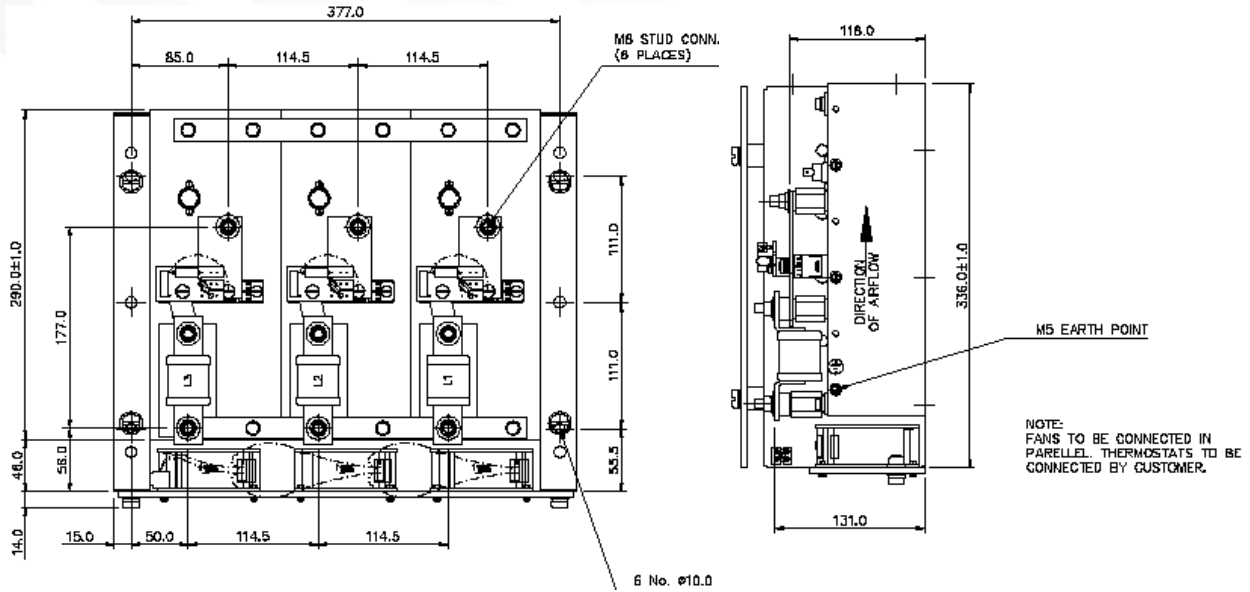

Connection :- (do not touch inhibit link T1 & T2)
 the three yellow dots are the input
 the three black dots are the output
 T3 0-10V input
 T4 0-10V input
 T5 0V
 T6 0V

NOTE: It is imperative that the power connections are fully tightened, without excessive force, and ensure the maximum area of cable is in contact with the terminals.

AX-PPR3-180-280-400

180/280/400kW Three Phase Power Regulators



AX-PPR3-400 Dimensions

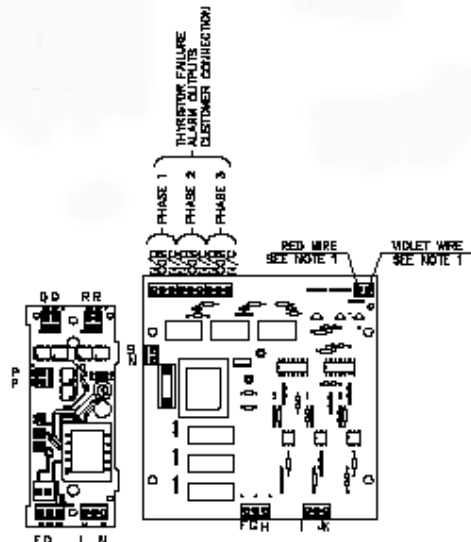
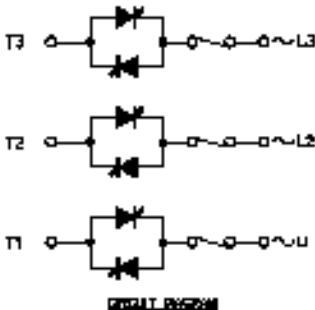
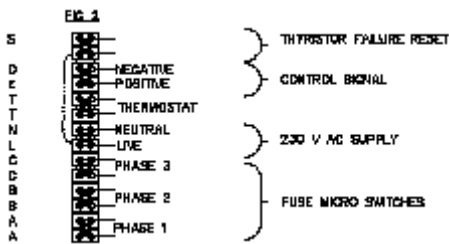
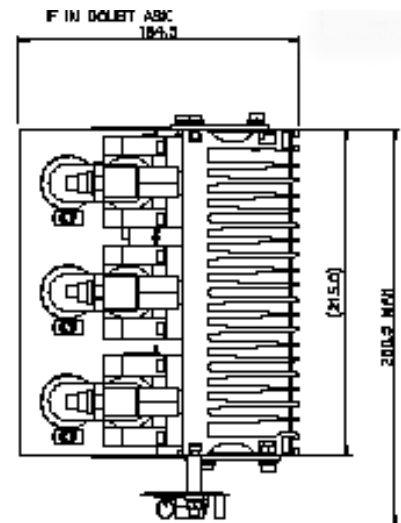
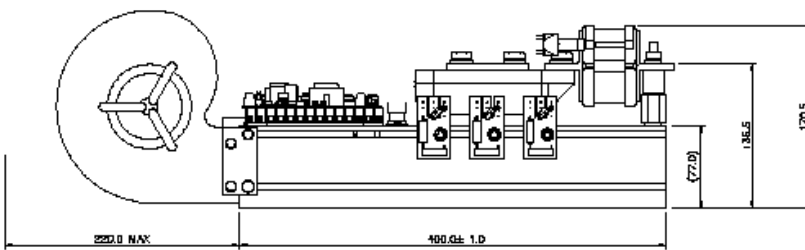
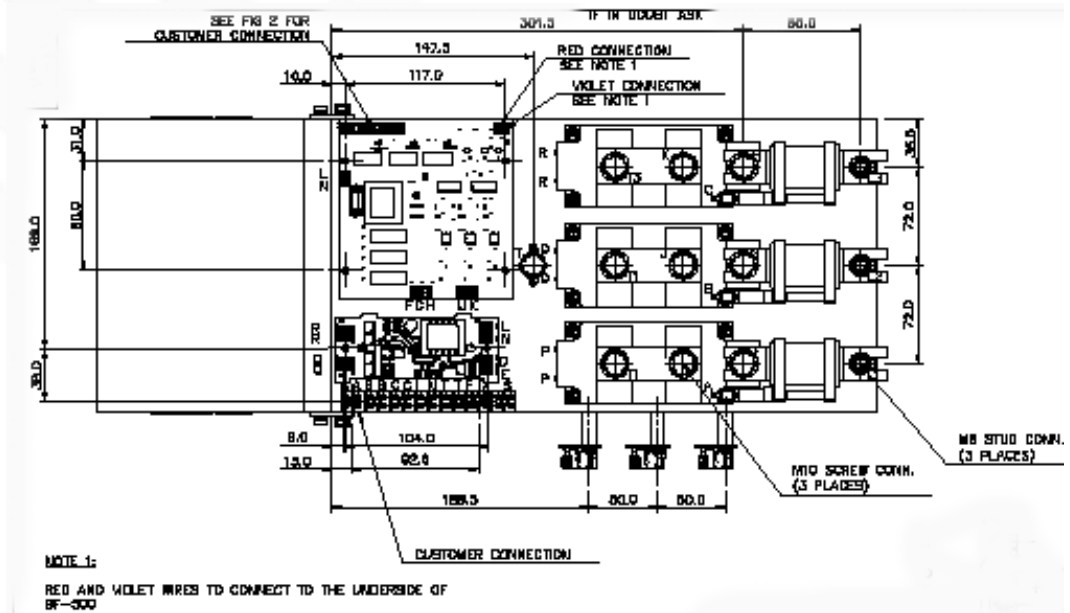

NOTE: It is imperative that the power connections are fully tightened, without excessive force, and ensure the maximum area of cable is in contact with the terminals.

AX-PPR3-180-280-400

180/280/400kW Three Phase Power Regulators



280kW Power Controller

For units up to a current load of 400 Amps at 45°C

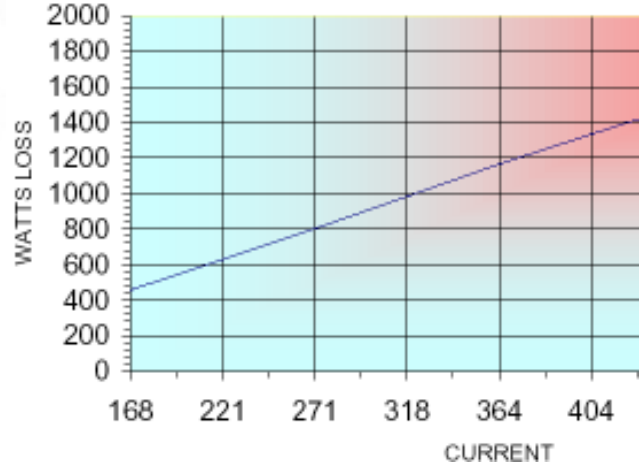
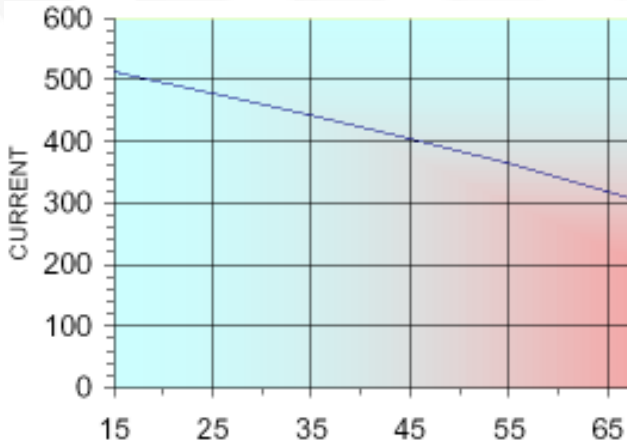

400kW Power Controller

For units up to a current load of 620 Amps at 45°C

Current / Ambient Temperature

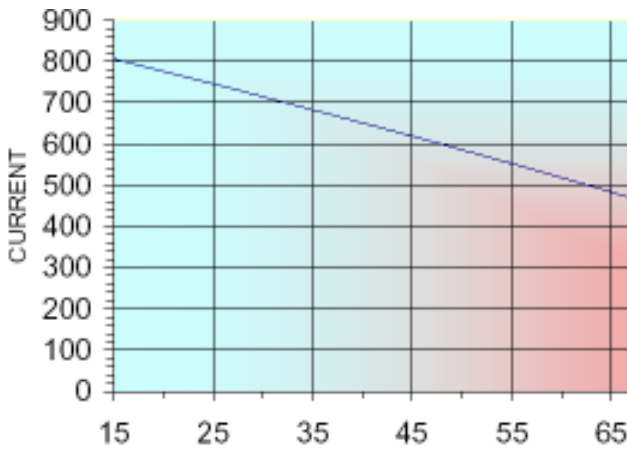

Dissipated Heat

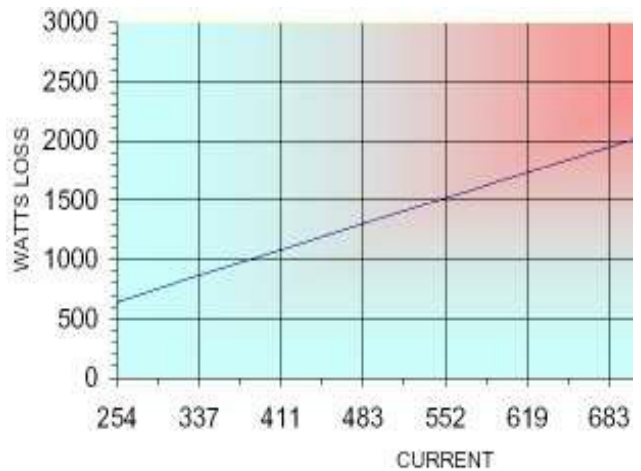

Fusing Electrical Characteristics

Type	Rated Current RMS-Amps	I²t (A²S)			Watts Loss	Part Number
		Pre-arc	Clearing at 415V	Clearing at 660V		
MT†	160	2400	15000	25000	26	160MT
	180	3800	25000	38000	26	180MT
	200	6000	40000	58000	27	200MT
	250	11500	80000	110000	32	250MT
	280	16500	100000	150000	35	280MT
	315	19000	125000	180000	42	315MT
	355	22000	160000	200000	51	355MT
MMT†	180	1650	12000	18000	42	180MMT
	200	2200	16000	23000	42	200MMT
	225	3700	26000	40000	42	225MMT
	280	6600	47000	70000	47	280MMT
	315	8600	62000	91000	51	315MMT
	355	13500	97000	140000	54	355MMT
	400	21000	150000	220000	60	400MMT
	450	30000	220000	320000	57	450MMT
	500	42000	300000	450000	84	500MMT
	560	60000	430000	640000	64	560MMT
630	68500	500000	720000	86	630MMT	
710	78000	600000	850000	105	710MMT	

AX-PPR3-180-280-400

180/280/400kW Three Phase Power Regulators



INPUT SELECTION SWITCH

INPUT	SM1	SM2	SM3	SM4
0-10V	0	1	0	0
0-5V	0	0	0	0
4-20mA	1	0	1	1

BF500

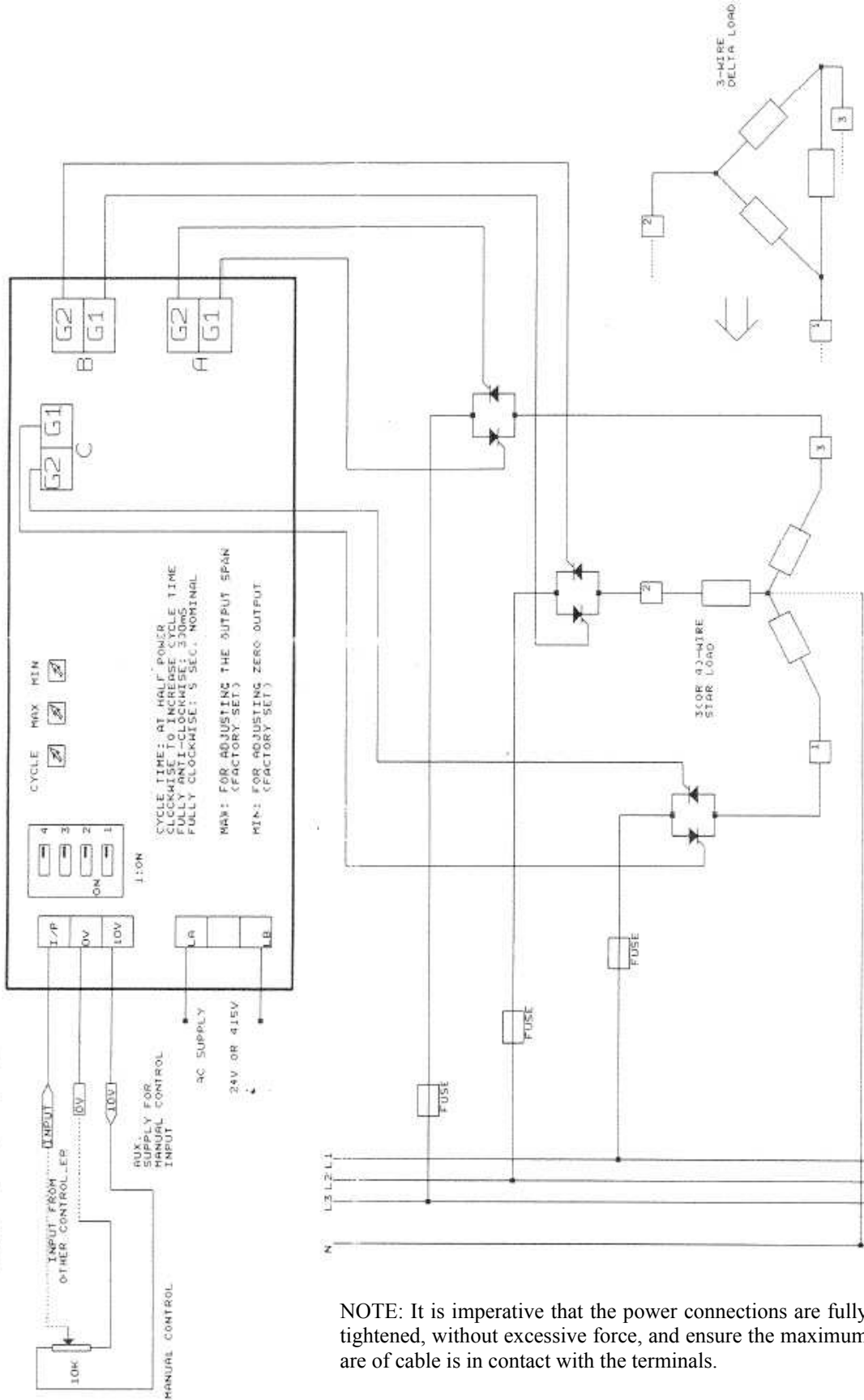

NOTE: It is imperative that the power connections are fully tightened, without excessive force, and ensure the maximum are of cable is in contact with the terminals.

Every effort has been taken in the production of this data sheet to ensure accuracy. Axio do not accept responsibility for any damage, expense, injury, loss or consequential loss resulting from any errors or omissions. Axio has a policy of continuous improvement and reserves the right to change this specification without notice.