

Product Overview

The AX-LFS range of electro-mechanical flow switches is intended for flow control of water or corrosive media in heating and cooling systems. They are well suited for pipes used in industrial plants, such as heating and air conditioning systems, refrigeration systems sprinkler or anti-fire systems, heat pumps, devices for oil monitoring and lubrication circuits. They have a built in safety switch with an alarm signal for flow shortage signaling.



Products Features

- Pipe sizes 1” to 8” or 1/2”, 3/4”, 1” with T fitting
- Available for use in seawater or corrosive media
- Adjustable or fixed hysteresis
- Breaking capacity 15(8) A at 230 V AC
- Protection class IP65
- Models with TÜV approval available

Product Specifications

Contacts	Dust-tight microswitch with switching contacts (NC/NO)
Switch capacity	24 - 230 Vac/ 15A (resistive load) or 8A (inductive load)
Operating temperature	-40 - +85°C
Humidity	10 - 90 % RH (non-condensing)
Max. liquid temperature	-40 - +120°C
Fitting	See flow rate table
Process connection	1” BSPT
Paddles	Stainless steel AISI 316L
Housing	Base in ABS, transparent Polycarbonate (PC) cover
Protection class	IP65 class I
Size	140 x 62 x 65 mm
Certification	EU LVD, EU EMC, Eu RoHS
Country of Origin	Sweden

Product Order Codes

Type	Pipe	Max Pressure	Normal media (body in brass)	Corrosive media (body in stainless steel AISI 316L)	“T” pipe fitting	Flow rate	TÜV approved
AX- LFS-B1	ø1...8”	11 bar	•			1	
AX- LFS-B1A	ø1...8”	11 bar	•			1	•
AX- LFS-B2	ø1...8”	11 bar	•			2	
AX- LFS-S1A	ø1...8”	30 bar		•		1	•
AX- LFS-S2	ø1...8”	30 bar		•		2	
AX-LFS-B3T1	ø1/2”	11 bar	•		•	3	
AX-LFS-B3T2	ø3/4”	11 bar	•		•	3	
AX-LFS-B3T3	ø1”	11 bar	•		•	3	

Installation

The flow switch can be installed in either a horizontal or vertical position. It must be fitted away from any pipe elbows or choke points. If the paddle is located close to the bottom of the pipe, care should be taken to ensure that the pipe is free from slag. The device should be mounted so that the arrows match the flow direction of the media inside the pipe (see picture).

If the pipe is vertical, the range of the flow switch must be re calibrated so that the paddle weight is properly balanced.

If fitted for downward flow, AX-LFS must be installed in a straight pipe, far from any filters or valves, etc. An unimpeded length of pipe at least 5 times the pipe diameter must be available both upstream and downstream of the unit.

Note: If the flow switch is used as a minimum flow controller, it is necessary to add another device downstream of the first one for alarm condition activation.

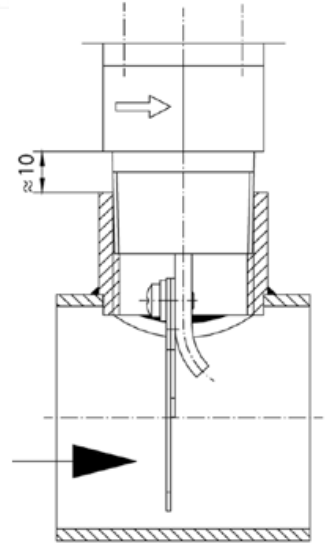

H₂O flow rate AX- LFS-B1/B1A/S1A

Pipe Connector	Qmax (m ³ /h) recommended	Min. adjustment (m ³ /h) Cut-off (Cut-in)	Max. adjustment (m ³ /h) Cut-off (Cut-in)
ø 1"	3.6	0.6 (1.0)	2.0 (2.1)
ø 1 1/4"	6.0	0.8 (1.3)	2.8 (3.0)
ø 1 1/2"	9.0	1.1 (1.7)	3.7 (4.0)
ø 2"	15.0	2.2 (3.1)	5.7 (6.1)
ø 2 1/2"	24.0	2.7 (4.0)	6.5 (7.0)
ø 3"	36.0	4.3 (6.2)	10.7 (11.4)
ø 4"	60.0	11.4 (14.7)	27.7 (29.0)
ø 4"Z*	60.0	6.1 (8.0)	17.3 (18.4)
ø 5"	94.0	22.9 (28.4)	53.3 (55.6)
ø 5" Z*	94.0	9.3 (12.9)	25.2 (26.8)
ø 6"	120.0	35.9 (43.1)	81.7 (85.1)
ø 6" Z*	120.0	12.3 (16.8)	30.6 (32.7)
ø 8"	240.0	72.6 (85.1)	165.7 (172.5)
ø 8" Z*	240.0	38.6 (46.5)	90.8 (94.2)

H₂O flow rate AX- LFS-S2 / B2

Pipe Connector	Min. adjustment (m ³ /h) Cut-off (Cut-in)	Max. adjustment (m ³ /h) Cut-off (Cut-in)
ø 1"	0.2 (0.6)	1.0 (1.1)
ø 1 1/4"	0.25 (0.9)	1.4 (1.6)
ø 1 1/2"	0.25 (0.9)	1.6 (2.2)
ø 2"	0.9 (2.3)	3.6 (4.1)
ø 2 1/2"	1.2 (3.1)	4.9 (5.5)
ø 3"	2.1 (4.9)	7.4 (8.2)
ø 4"	4.9 (11.3)	17.1 (19.1)
ø 4"Z*	3.3 (7.7)	11.6 (13.0)
ø 5"	9.7 (22.4)	34.0 (37.9)
ø 5" Z*	5.0 (11.5)	17.5 (19.6)
ø 6"	13.6 (31.5)	47.6 (53.2)
ø 6" Z*	ø 6.1 (14.1)	21.4 (23.9)
ø 8"	25.7 (59.6)	90.1 (100.7)
ø 8" Z*	21.7 (36.5)	55.3 (61.8)

*For these models, the longest paddle must be used in order to obtain the values indicated in the table. Pressure drop at the maximum flow (Qmax): 0.08 bar

"T" pipe fitting flow rate AX-LFS-B3T1/B3T2/B3T3

DBSF	Pipe connector with "T" pipe fitting	Min. adjustment (m ³ /h) Cut-off (Cut-in)	Max. adjustment (m ³ /h) (Cut-off (Cut-in))
3E	ø 1/2"	0.174 (0.48)	0.846 (0.948)
4E	ø 3/4"	0.138 (0.408)	0.768 (0.858)
6E	ø 1"	0.2 (0.6)	1.0 (1.1)

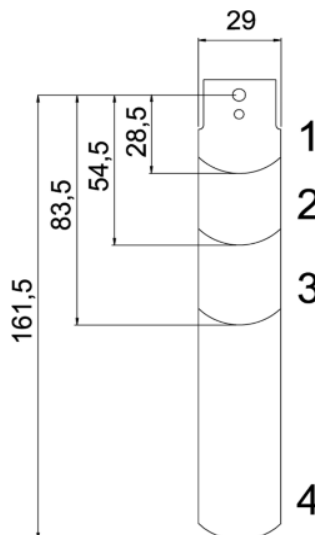

Paddles (models without "T" pipe fitting)

Pipe	Paddles
1"	1
1 1/4"	1
1 1/2"	1
2"	1.2
2 1/2"	1.2
3"	1.2.3
4"	1.2.3
4" Z	1.2.3.4
5"	1.2.3
5"Z	1.2.3.4
6"	1.2.3
6" Z	1.2.3.4
8"	1.2.3
8" Z	1.2.3.4

Dimensions (mm)

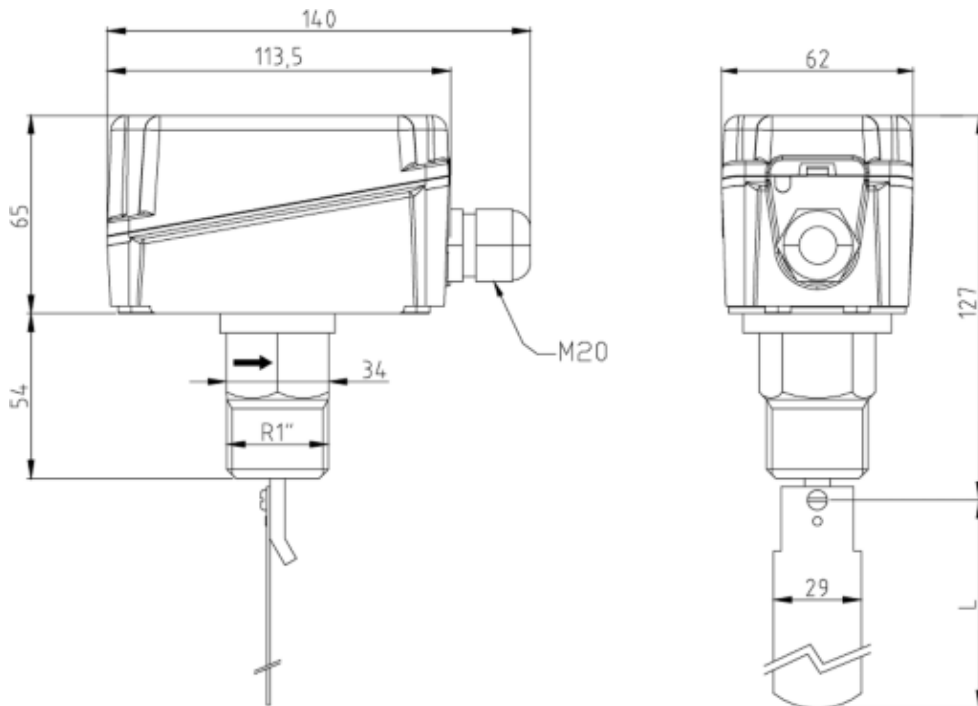

Wiring

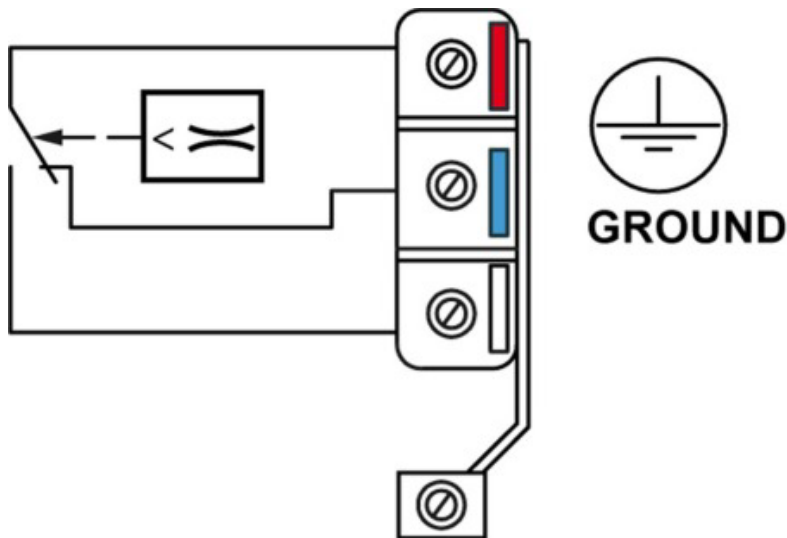

Connect to the red and white contacts of the micro switch. They will open when the flow drops below the set level. When no flow is present, the red/blue contacts will close and can be used for a signal or alarm.

Datasheet Contents

Every effort has been taken in the production of this data sheet to ensure accuracy. Annicom do not accept responsibility for any damage, expense, injury, loss or consequential loss resulting from any errors or omissions. Annicom has a policy of continuous improvement and reserves the right to change this specification without notice.