

AX-GS-CD-D80

Duct Carbon Dioxide Sensors



Product overview

The AX-GS-CD-D80 Carbon Dioxide Duct mounted Transmitter uses single beam Infra-red technology to monitor CO2 concentration levels and output a corresponding 0-10V signal. The unit is intended for use in return air ducts, to give a proportional signal to control ventilation and hence maintain air quality. The -AR versions have an adjustable switched relay output to directly control a fan.

Various passive temperature sensors are available as an option.



Products Features

- Duct mounting, with range of power supply options
- Monitors CO2 over range of 0-2,000ppm
- Options of 105 and 205mm probe lengths
- Relay switched output versions available
- Lifetime calibration
- Gas permeable PTFE filter

Product Specifications

Power Supply:	D8041, D8042	AC: 18 to 30Vac 50/60Hz DC: 18 to 42Vdc (0.65W @ 42Vdc ,1.65W peak power)
	D8041-230, D8042-230	90 to 265Vac (0.7W ,1.7W peak power)
	-AR versions	24V ac or dc \pm 15% (1.5W max @ 24Vdc)
Ambient Temperature Range:		0 to +50°C, 0-95% RH non condensing
Analogue Output:		0-10V at 5mA maximum. Resolution <25mV steps
Output Range:		0-2,000ppm for 0-10V signal
Accuracy:		\pm 40ppm or 3% whichever is greater at 22°C
Stability:		Self Calibrating <2% FS over life of sensor (typical 10 years)
Linearity:		<1% FS @ 22°C
Duct Air Velocity:		0 - 450m/min
Relay output:		CO contact rated 5A (NO) resistive at 250Vac ,100mA min load
Relay adjustment:		Independent on and off adjustable between 200-2000ppm
Enclosure:		Flame retardant ABS (UL 94 - 5VA). Protection IP30
Dimensions:		Refer to drawing on page 2
Sensor Type:		Non-dispersive Infra-red
Calibration:		Field calibration will not be required. See ABC Logic
Expected Lifetime:		10 Years
Conformity:		CE marked, EMC, LVD
Country of Origin:		UK

Order Codes

AX-GS-CD-D8041	Duct Mounted CO2 Sensor, 105mm probe, 24V supply
AX-GS-CD-D8042	Duct Mounted CO2 Sensor, 205mm probe, 24V supply
AX-GS-CD-D8041-AR	Duct Mounted CO2 Sensor, 105mm probe, 24V supply, Adjustable relay output
AX-GS-CD-D8042-AR	Duct Mounted CO2 Sensor, 205mm probe, 24V supply, Adjustable relay output
AX-GS-CD-D8041-230	Duct Mounted CO2 Sensor, 105mm probe, 230V supply
AX-GS-CD-D8042-230	Duct Mounted CO2 Sensor, 205mm probe, 230V supply

AX-GS-CD-D8041(2)-x and **AX-GS-CD-D8041(2)-230-x** versions available with additional passive temperature sensor output. See next page for passive temperature sensor selection

AX-GS-CD-D80

Duct Carbon Dioxide Sensors



Thermistor/Element Codes. Replace 'x' in AX-GS-CD-D8041(2)-x and AX-GS-CD-D8041(2)-230-x and with bold code below

Code	System Examples	Element	Code	System Examples	Element
T	Trend, Innotech , Priva , Trane	10K3A1 NTC	50K	Priva	50K6A1 NTC
3K	Alerton	3K3A1 NTC	J	Johnsons	2.2K NTC
A	York, Alerton	10K4A1 NTC	100	Serek	PT100a Platinum
H	Honeywell	20K6A1 NTC	1K	Cylon	PT1000a Platinum
D	Drayton	30K6A1 NTC	N1K	Siemens	Ni1000a Nickel (TCR)
SAT	Satchwell (SAT1)	SAT1 NTC	TAC	TAC	1K87A1 NTC
ST1	Staefa(ST1)	ST1 PTC			

Dimensions

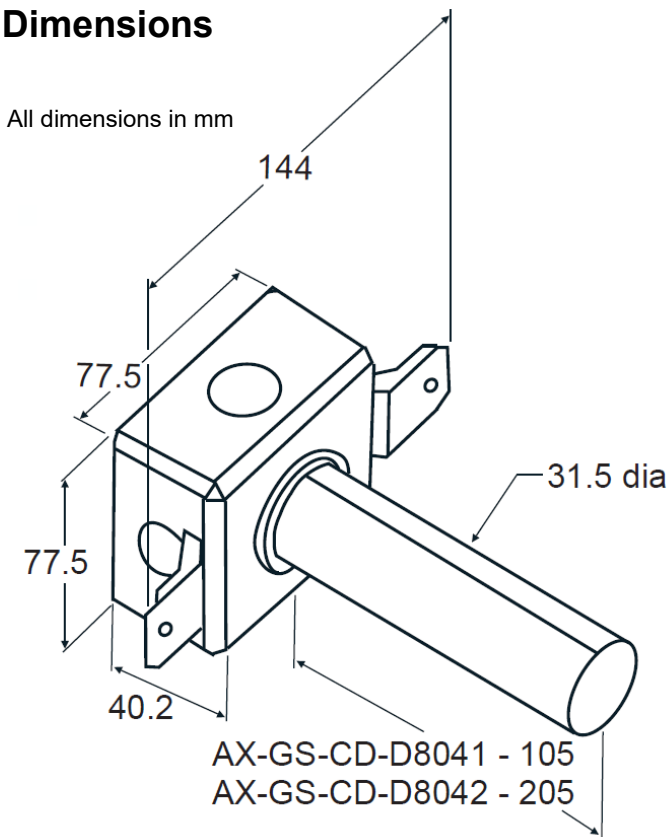

Connections

• AX-GS-CD-D8041(2) (-x)

The transmitter should be connected to the controller using 0.5 to 1.5mm² cables. The use of a shielded cable is recommended for the highest noise immunity.

The transmitter can work with both ac and dc power supplies. If a dc power supply is used, ensure that it is galvanically isolated from the mains power. It can also be powered by a step-down transformer if mains voltage is available (Annicom recommends the use of a 5VA transformer). Ensure that the device's maximum ratings are not exceeded. Excess voltage will result in permanent damage. Do NOT apply any external voltage to the OUT terminal.

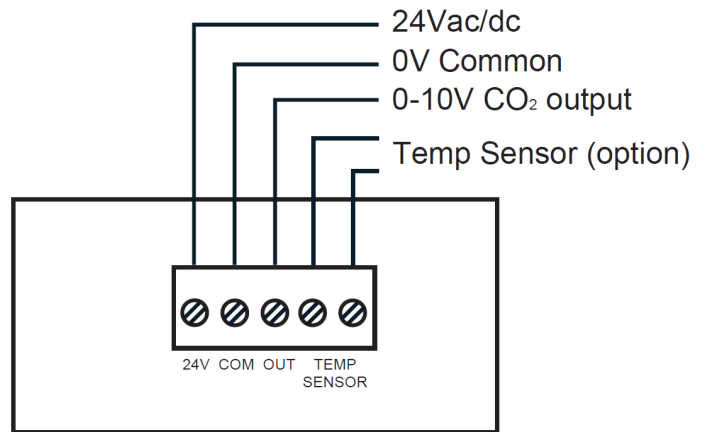

• AX-GS-CD-D8041(2)-230(-x)

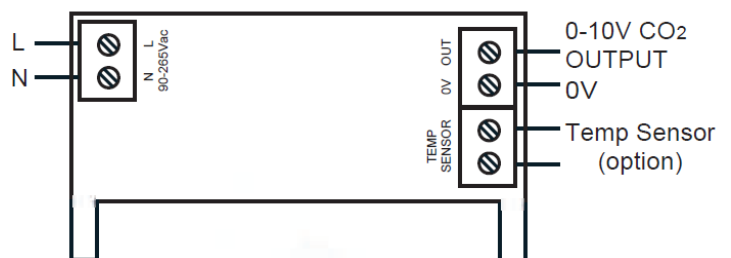

Installation

The sensor should be installed by a suitably qualified technician in conjunction with any guidelines for the equipment it is to be connected to and any local regulations. Damages caused to the device due to improper installation or not adhering to the product specifications will not be covered under warranty.

The Duct sensor includes mounting screws to enable installation directly on to the duct.

- Take note of the arrows moulded inside the terminal box which indicate the direction of air flow.
- Drill a 38.10 mm hole for the probe and two 3.17mm holes for mounting screws on the duct
- Slide the probe into the hole and secure the sensor with screws.
- Make necessary wire connections and install the lid.

- **AX-GS-CD-D8041(2)-AR**

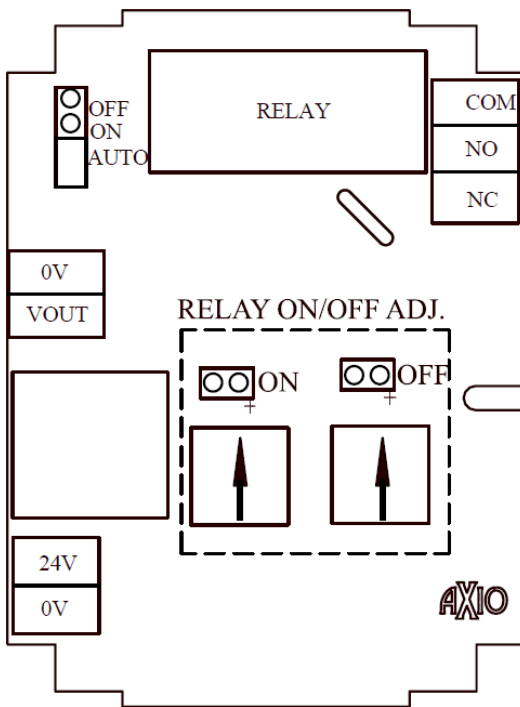

concentrated points, it performs a statistical analysis to see if there has been any small changes in the sensor reading over background levels that could be attributable to sensor drift. If the analysis concludes there is drift, a small correction factor is made to the sensor calibration to adjust to this change.

Note - this sensor should NOT be used where it does not experience a periodic drop to outside levels (i.e. where occupancy is 24 Hrs/ 7 days/week).

Datasheet Contents

Every effort has been taken in the production of this data sheet to ensure accuracy. Annicom do not accept responsibility for any damage, expense, injury, loss or consequential loss resulting from any errors or omissions. Annicom has a policy of continuous improvement and reserves the right to change this specification without notice.

The -AR version comes with an adjustable relay output apart from the analogue voltage output for CO₂. The relay has adjustable ON and OFF settings. The factory set values are relay ON at 800ppm and OFF at 700ppm. Adjustments can be made using the ON and OFF potentiometers, whilst monitoring the voltage switch point on the pins marked ON and OFF. Always set the OFF voltage below the ON voltage for correct operation.

E.g. Setting Relay ON at 1000ppm CO₂ and OFF at 800ppm CO₂

The CO₂ transmitter is 0-10VDC scaled for the range 0-2000ppm CO₂

Voltage output for 1000ppm = 5Vdc

Voltage output for 800ppm = 4Vdc

Measure the voltage across 'ON' pins using a DMM and adjust it to 5V by adjusting the corresponding potentiometer. Similarly, adjust the voltage at 'OFF' terminals to 4V.

The relay will now switch ON at 1000ppm. This can be used to control the ventilation fan. It will be switched OFF when the CO₂ reading falls below 800ppm.

Operation

ABC Logic and Lifetime Guarantee

The ABC (Automatic Background Calibration) program utilises the computing power in the sensors onboard microprocessor to remember the lowest CO₂ concentration that takes place every 24 hours. The sensor assumes this low point is at outside levels. The sensor is also smart enough to discount periodic elevated readings that might occur if for example a space was used 24 hours a day over a few days. Once the sensor has collected 14 days worth of low