

AX-ECFAN3

Three Speed to EC Fan Converter - 24Vac/dc & 230Vac Versions



Product overview

The AX-ECFAN3 provides an effective, affordable method for interfacing 3 Speed Thermostats with EC fans.

The unit accepts three 24Vac/dc or 230Vac switched inputs, and converts these to a 0-10Vdc output. Each of the three inputs can be adjusted to provide a different voltage output between 0 and 10 Volts DC.

The enclosure is IP65 flame retardant ABS. All terminals are two-part, rising clamp terminals for ease of connection.

Features

- 3x 24V / 230Vac inputs each converted to 0-10Vdc
- Adjustable 0-10Vdc Output for each channel
- 24Vac/dc or 230Vac Versions
- Flame retardant ABS moulded enclosure

Product specifications

Input select voltages:	AX-ECFAN3-24	3 off 24Vac $\pm 15\%$ or 24Vdc $\pm 15\%$ at 4.4K Ω nominal load (load current can be increased to 470 Ω by jumper selection)
	AX-ECFAN3-230	3 off 230Vac $\pm 15\%$ at 1.5mA nominal (note, some triac switches may not switch this load correctly)
Output voltage when selected:		Adjustable between 0-10Vdc at 5mA maximum
Output voltage when off:		<0.1Vdc at 5mA maximum
Supply voltage:	AX-ECFAN3-24	24Vac 50/60Hz $\pm 15\%$ or 24Vdc $\pm 15\%$ at 25mA maximum
	AX-ECFAN3-230	230Vac $\pm 15\%$
Output isolation:	AX-ECFAN3-230	4kV minimum
Terminals:		Two-part rising clamp for 0.5-1.5mm ² cable
Ambient temperature range:		0-50°C
Dimensions:		92mm diameter x 52mm height
Fixing holes:		2 off 4mm holes on 92mm centres
Housing:		IP65 flame retardant ABS
Country of origin:		United Kingdom

Order codes

AX-ECFAN3-24	Three Speed to EC Fan Converter - 24Vac/dc Version
AX-ECFAN3-230	Three Speed to EC Fan Converter - 230Vac Version

© Copyright Annicom 2018. All Rights Reserved

Annicom Ltd

Unit 21 Highview | Bordon | Hampshire | GU35 0AX

t: +44 (0)1420 487788 | f: +44 (0)1420 487799 | orders@annicom.com

AX-ECFAN3

Three Speed to EC Fan Converter - 24Vac/dc & 230Vac Versions



Installation

The AX-ECFAN3 should be installed by a suitably qualified technician in conjunction with any guidelines for the equipment it is to be connected to. Field wiring should be installed to satisfy the requirements set out by the manufacturer of the equipment that the module is being connected to.

Connections

AX-ECFAN3-230

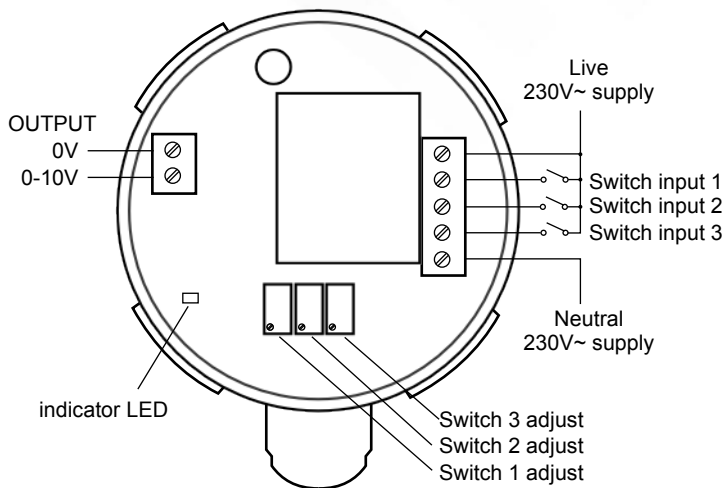

Setup

With none of the inputs selected, the output will be 0V.

When the supply is applied to the 'Switch input 1', the 0-10V output is as set by the 'Switch 1 adjust' potentiometer.

When the supply is applied to the 'Switch input 2', the 0-10V output is as set by the 'Switch 2 adjust' potentiometer.

When the supply is applied to the 'Switch input 3', the 0-10V output is as set by the 'Switch 3 adjust' potentiometer.

If at any time more than one input is selected, then the 0-10V output defaults to the higher of the inputs.

The on-board indicator LED will flash in short bursts to indicate which input is selected.

AX-ECFAN3-24
typical installation shown

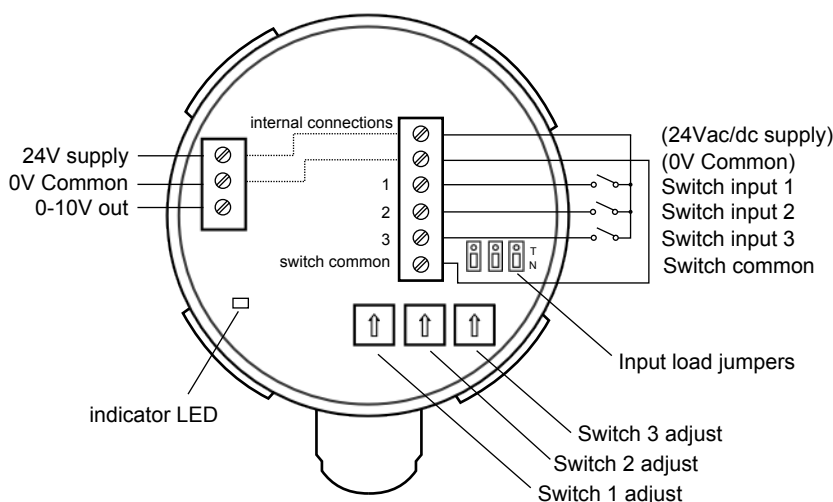

Fixing details

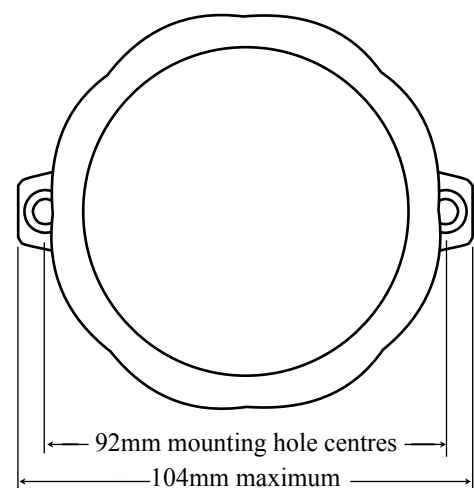

If input switching is by means of triacs, and the loading is insufficient for the triacs to operate correctly, move the 'input load jumpers' from position N to position T

Every effort has been taken in the production of this data sheet to ensure accuracy. Axio do not accept responsibility for any damage, expense, injury, loss or consequential loss resulting from any errors or omissions. Axio has a policy of continuous improvement and reserves the right to change this specification without notice.