



Product Overview

The AX-DASM range of damper actuators are designed to be used for the operation of dampers, valves and other process control elements. The DASM series of actuators remain in position in the event of power failure. Direct mounting of the actuator onto the damper shafts is achieved using the mounting clamp.

Features

- Constant running time , independant of load
- Very quiet operation >30db(A)
- Floating control
- 0- 10 proportional version available
- Automatic shutoff at endstop
- Simple manual positioning via red button

Product Specifications

Output:		30nm
Output Modes:	F	Floating point (Raise Lower)
	SF	Proportional 0 to 10Vdc
Power Supply:	F	230Vac +/- 15%
	SF	24Vac /dc only +/- 20%
Running Time:		120/240 secs +/- 5% for 90 deg rotation
Power Consumption:	F	3.7W 4.7VA
	SF	2.4W 4.3VA
Angle of Rotation:		90 deg max 95 deg
Noise Emission Level:		> 30db (A)
Spindle Size:	Circular	12 to 20mm diam
	Square	10 to 16mm
Connection:		1.2m cable
Protection:		IP54
Ambient Temp. Range:		-20 to + 55°C @ 5 to 85 % RH
Weight:	F	1800 gms approx
	SF	1600 gms approx
Country of Origin:		Switzerland

Dimensions

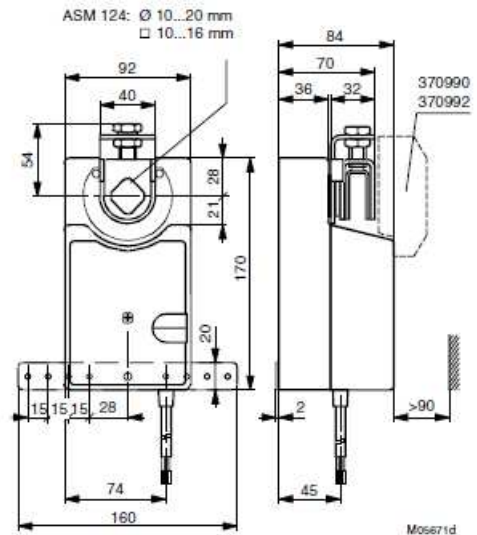

Order Codes

AX-DASM134F130	Floating point Damper Actuator 30nm 230Vac/dc 120/240sec
AX-DASM134SF132	Proportional Damper Actuator 30nm 24Vac/dc 120/240 secs

Floating Point Control

Operation

By connecting the power supply to either cable 2a or cable 2b, the final control element can be moved into any desired position.

The coupling piece turns (as viewed from the actuator towards the spindle adaptor) in a clockwise direction if power is connected to the brown wire (2a), and in an anti-clockwise direction if connected to the black wire (2b).

The electronic motor cut-out comes into operation (no limit switches) in both end positions (on reaching the damper stop, or if stopped by the rotation-angle limiter, or on reaching the maximum angle of 92°) or in the event of an overload.

The running time can be matched to requirements using switches S1 and S2. Manual adjustment by turning the spindle adaptor after de-coupling the gears (button on housing cover)

The direction of rotation can be changed by swapping the power-supply wires over.

Engineering and fitting notes

The concept of combining stepping motor and electronics allows several dampers with different torque levels to be run in parallel. The actuator can be mounted in any position, can be inserted directly onto the damper shaft and is fixed using the self-centring clamp.

N.B.: The housing should not be opened.

The following accessories can be fitted to each actuator: one set of single auxiliary contacts or one set of double auxiliary contacts or one potentiometer. On the ASM 134, this type of accessory cannot be fitted if the length of the damper spindle is < 52mm. By re-positioning a disc under the coupling piece, the angle of rotation can be limited between 0 and 90° in steps of 5°. The coupling piece on the is suitable for damper spindles of Ø 12...20 mm and □ 10...16 mm.

Fitting outdoors. If the devices are fitted outdoors, we recommend that additional measures be taken to protect them against the effects of the weather.

Coding switches

90°	S1	S2	S3
240 s	off	on	–
120 s	on	on	–
120 s	on	off	–
240 s	off	off	–
ex-works position	on	on	on

Additional technical data

The upper part of the housing, with the lid, manual-adjustment knob and the cap, contains the stepping motor and the SUT electronic control unit. The lower part contains the maintenance-free gears and the spindle adaptor. To reverse the direction of operation, the brown and the black wires should be transposed.

Auxiliary change-over contacts

Switch rating: max. 230 V a.c.; min. current 20 mA at 20 V

Switch rating: max. 4...30 V d.c.; min. current 1...100 mA

Connection

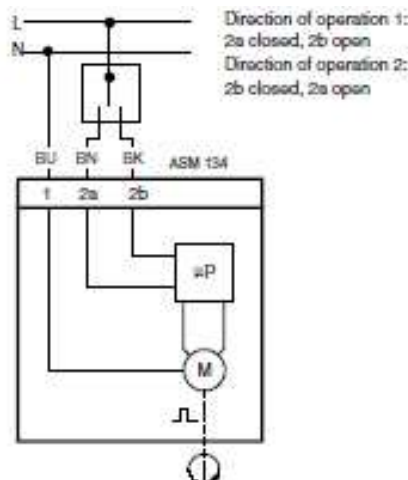

Options

Auxiliary switch

2 Auxiliary switch

Potentiometer

372145 001



A09782

372145 002

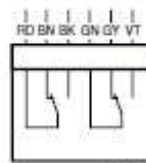

A10185

0372286

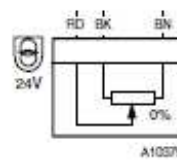

A10379

Proportional

Operation

Depending on how it is connected (see wiring diagram), the actuator can be used as a continuous 0...10 V, as a 2-point (open/close) or as a 3-point drive (open/stop/close) with intermediate position.

The running time can be matched to requirements using switches S1 and S2. Manual adjustment by turning the spindle adaptor after de-coupling the gears (button on housing cover)

Connected as a 2-point control unit

Open/close activation can be effected via two wires. Power is applied to the drive via the blue and the brown wires. On connecting power to the black wire (2b), the damper drive moves to the end position. When power is switched off, the drive goes to the opposite end position (clockwise direction to 100% angle of rotation).

The unused red and grey wires should not be connected, nor should they come into contact with other wires. We recommend that you insulate them.

Connected as a 3-point control unit

By connecting power to the wires (2a or 2b), the damper drive can be moved to any position. Angle of rotation (as viewed from the actuator towards the spindle adaptor):-

- The spindle adaptor turns in a clockwise direction if power is applied to the black wire (2b).
- The spindle adaptor turns in an anti-clockwise direction if power is applied to the brown wire (2a).

In the end positions (the damper's end position; the end position due to the angle-of-rotation limit; on reaching the maximum angle of rotation of 92°) or in the event of an overload, the electronic motor cut-off responds (no end switches). The direction of rotation can be changed by transposing the connections.

The unused red and grey wires should not be connected or come into contact with other wires. We recommend that they be insulated.

Connections for control voltage 0...10 V

The integrated positioner controls the drive as a function of the controller's positioning signal y.

Angle of rotation (as viewed from the actuator towards the spindle adaptor):-

Direction of operation 1 (mains power at brown wire, internal connection 2a): the spindle adaptor turns in a clockwise direction as the positioning signal rises.

Direction of operation 2 (mains power at black wire, internal connection 2b): the spindle adaptor turns in an anti-clockwise direction as the positioning signal rises.

The starting point and the control span are both pre-set.

Either the brown or the black wire should be connected, depending on the direction of operation. The unused wire should be insulated.

After power has been applied, the stepping motor moves to both stops one after the other and determines its effective angle of rotation (always with a running time of 60 seconds). Thanks to the electronics unit, no steps are lost, and the drive needs no periodical re-adjustment. After manual adjustments have been made, or when there is a power failure lasting longer than 5 minutes, the drive re-adjusts itself automatically. Whenever the angle of rotation is altered, a re-adjustment must be initiated (by manual adjustment) so that the drive, the control voltage and the feedback signal can adapt themselves to the new angle of rotation. Initialisation can be switched off using switch S3. The actuator then always uses the stops that were last saved. If it detects a new stop, it saves it, and the feedback signal is adapted accordingly. After an interruption to the power supply lasting longer than 5 minutes, the actuator works (without initialisation) from the current position. The current positioning value is issued as a feedback signal, until the drive moves to a stop and the current position can be calculated and issued.

If the control signal (0...10 V) is interrupted and direction of operation 1 is set, the damper closes fully (0% position).

Proportional

Coding switch

ASM 124S Running time	ASM 134S Running time	S1	S2	S3
120 s	240 s	off	on	–
120 s	120 s	on	on	–
60 s	120 s	on	off	–
60 s	240 s	off	off	–
Initialisation on		–	–	on
Initialisation off		–	–	off
Ex-works position		on	on	on

Split-range unit, accessory 361529 001

The starting point U_0 and the control span ΔU can be set using the potentiometer. This makes it possible to activate several regulating units in sequence or in cascade using the controller's control signal. The input signal (partial range) is amplified into an output signal of 0...10 V. This accessory cannot be fitted in the drive, but should be located externally in an electric distribution box.

Engineering and fitting notes

The combination of stepping motor and electronics allows several air dampers with different torque levels to be run in parallel, if drives of the same SUT type are used. The actuator can be mounted in any position, can be inserted directly onto the damper shaft and is fixed using the self-centring clamp. The damper spindle is turned by the self-centring spindle adaptor, which reduces the stress on the bearings.

N.B.: The housing should not be opened.

The coding switches are accessible via an opening with black lid in the housing cover.

The following accessories can be fitted to each actuator: one set of single auxiliary contacts or one set of double auxiliary contacts or one potentiometer. On the ASM 134, this type of accessory cannot be fitted if the length of the damper spindle is < 52 mm. By re-positioning a disc under the coupling piece, the angle of rotation can be limited between 0 and 90° in steps of 5°. The coupling piece on the ASM 124 is suitable for damper spindles of Ø 10...20 mm and □ 10...16 mm. The coupling piece on the ASM 134 is suitable for damper spindles of Ø 12...20 mm and □ 10...16 mm.

Fitting outdoors.

If the devices are fitted outdoors, we recommend that additional measures be taken to protect them against the effects of the weather.

Additional technical data

The upper part of the housing, with the lid, manual-adjustment knob and the cap, contains the stepping motor and the SUT electronic control unit. The lower part contains the maintenance-free gears and the spindle adaptor.

Auxiliary change-over contacts

Switch rating: max. 250 V a.c.; min. current 20 mA at 20 V

Switch rating: max. 30 V d.c.; min. current 1 mA at 4 V d.c.

Connection

